

# ABILICA XC 2700 MILL v5

## USER'S MANUAL

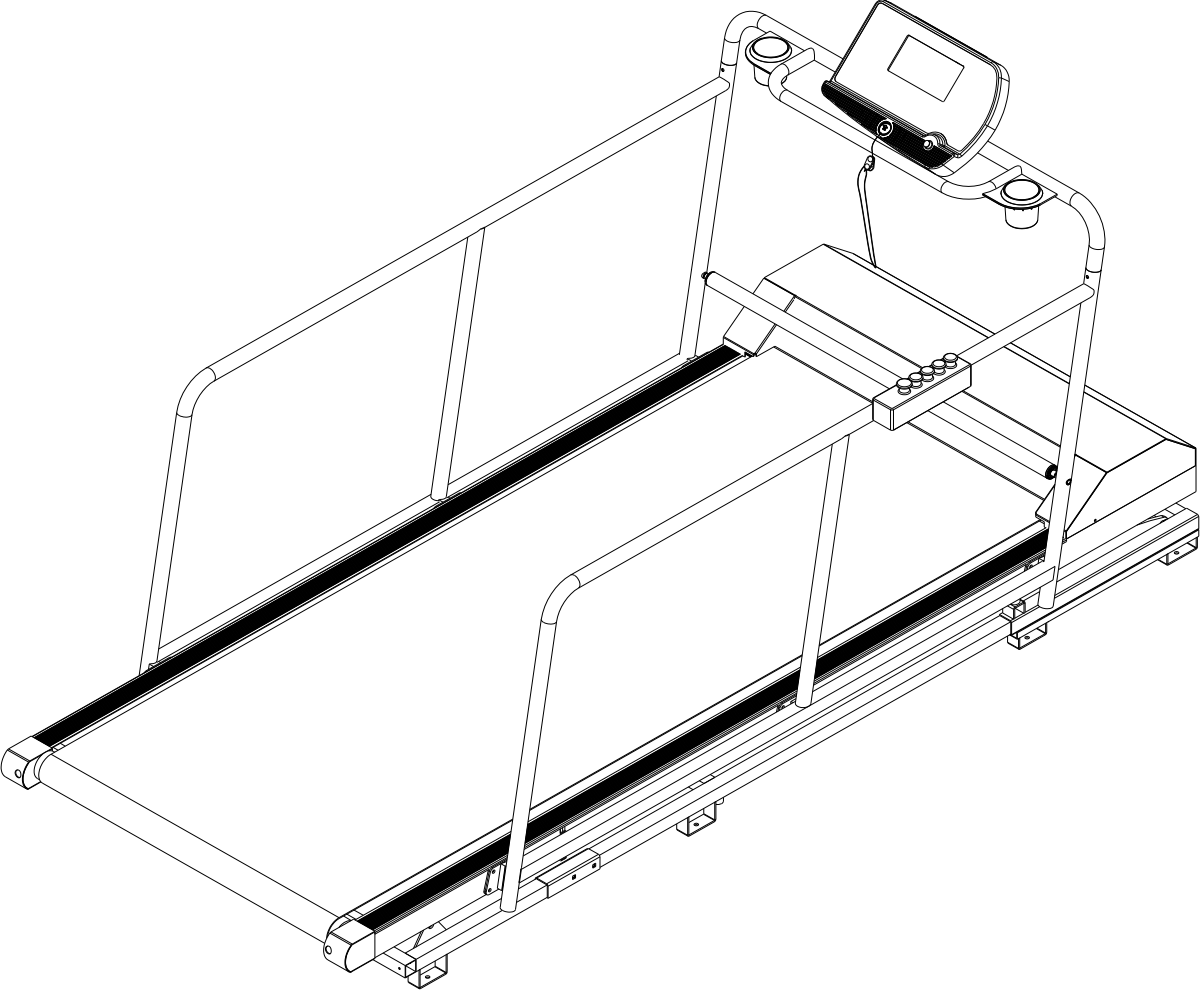

# PRODUCT OVERVIEW

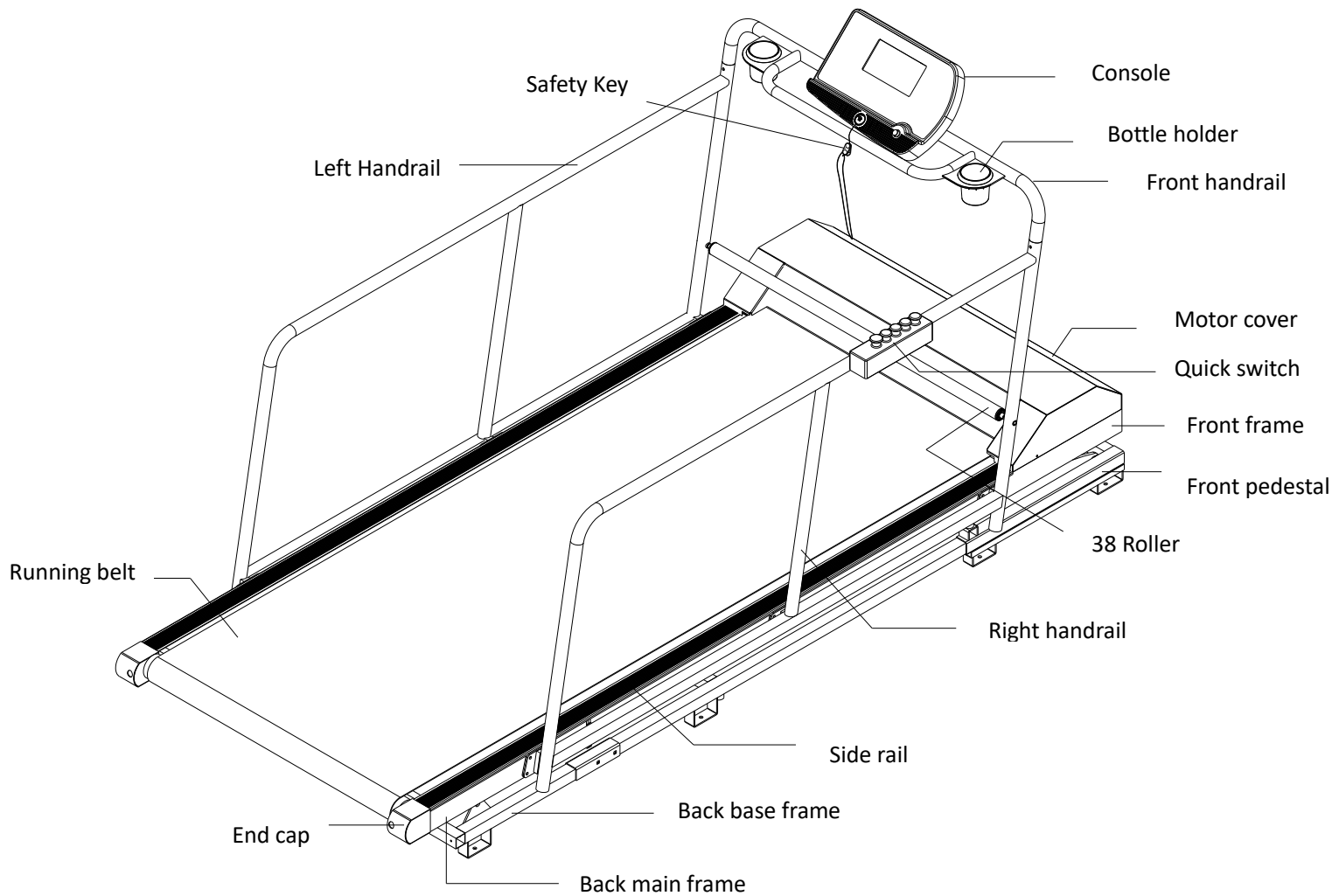



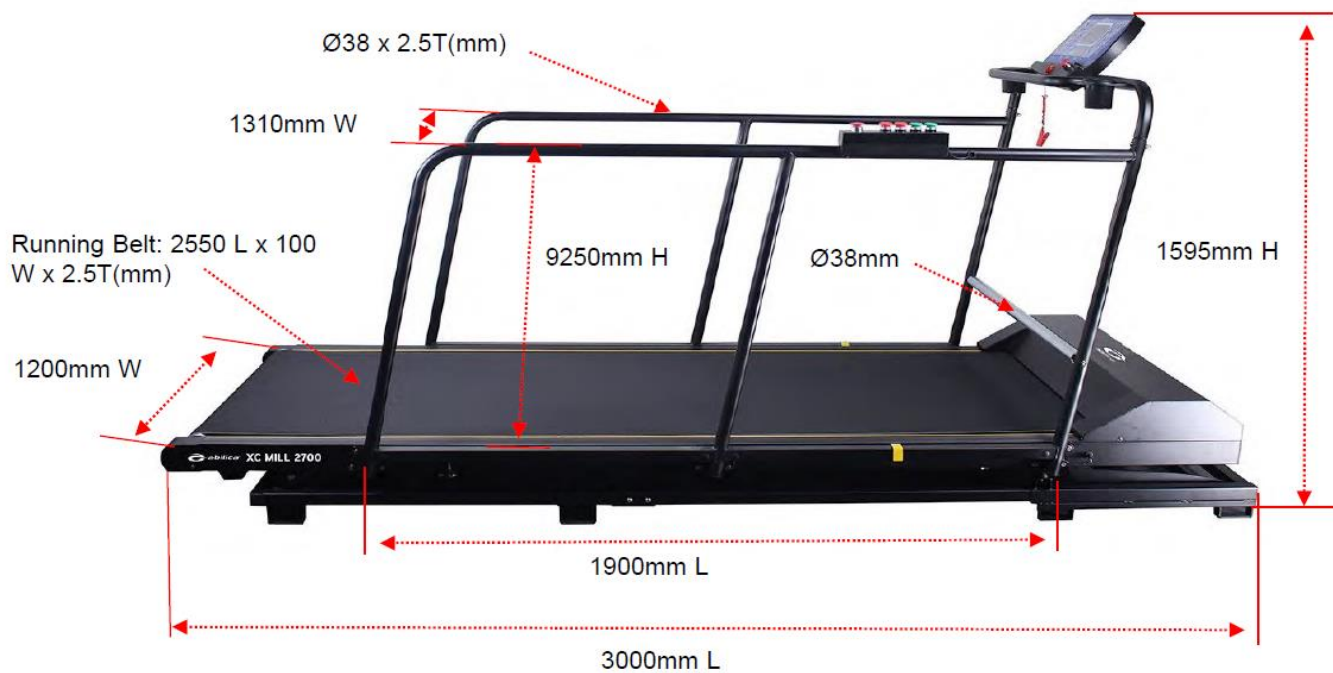



## Technical info



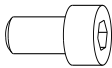
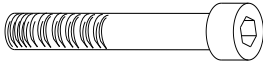
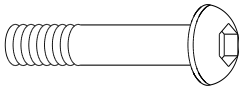
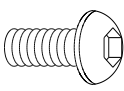

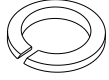

Overall Dimensions (mm):	3000 x 1310 x 1595
Running Surface (mm):	2550 L x 100 W x 2.5T
Class:	HB
Moter:	AC 4 HP
Speed Range:	1 ~ 30km/h
Incline:	15level 15%
Power input	220-240V AC
HZ:	50/60HZ
Volts:	180V
Current:	13,6A
RPM:	4500
Max User Weight (kg):	180
Folding:	NA
Max user weight (kg)	200
G.W.(kg):	270
N.W.(kg):	190

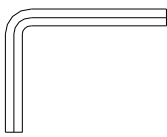
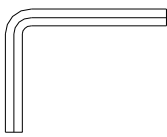
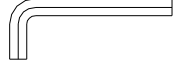
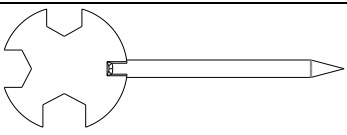
# HARDWARE

Note: Some bolts may be pre-installed.

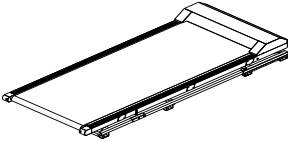
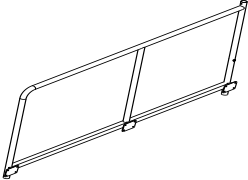
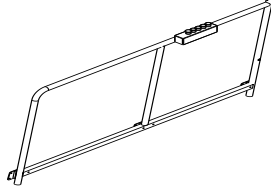
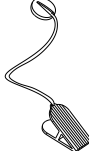
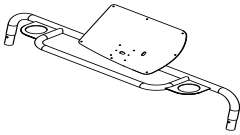
Illustrasjon	Nr.	Engelsk navn	Ant.
	D31	Hex round head bolt M8*20 mm	25
	D33	Hex round head bolt M8*60 mm	2
	D6	Round hex bolt M8*50 mm	2
	E12	Round hex bolt M8*30 mm	16
	D52	Cross bolt ST4.2*16mm	7
	D66	Small Curved Washer M8	2
	D67	Large Curved Washer M8	1
	D23	Flat washer M8	26
	D25	Spring washer M8	26
	D15	Cap Nut	2
	D2	Allen wrench 6mm	1
	D92	Allen wrench 8mm	1
	D3	Allen wrench 5mm	1
	D1	Cross wrench 13-15-17	1

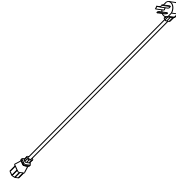
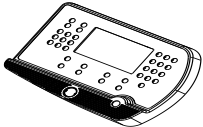
# ASSEMBLY PARTS

<p>Main frame 1pc</p> 	<p>A3L Left handrail 1pc</p> 	<p>A3R Right handrail 1pc</p> 	<p>C13 Safety Key 1pc</p> 
<p>A4 Front handrail 1pc</p> 	<p>B18 Silica gel 1pc</p> 	<p>B16 Water bottle holder 2pcs</p> 	<p>C15 Power cable 1pc</p> 
<p>B1 console 1pc</p> 	<p>B2 Plug 8pcs</p> 		

# ASSEMBLY INSTRUCTIONS

Remove all parts from packaging before you start assembling.

## STEP 1

Tilt the wooden case to upright position.

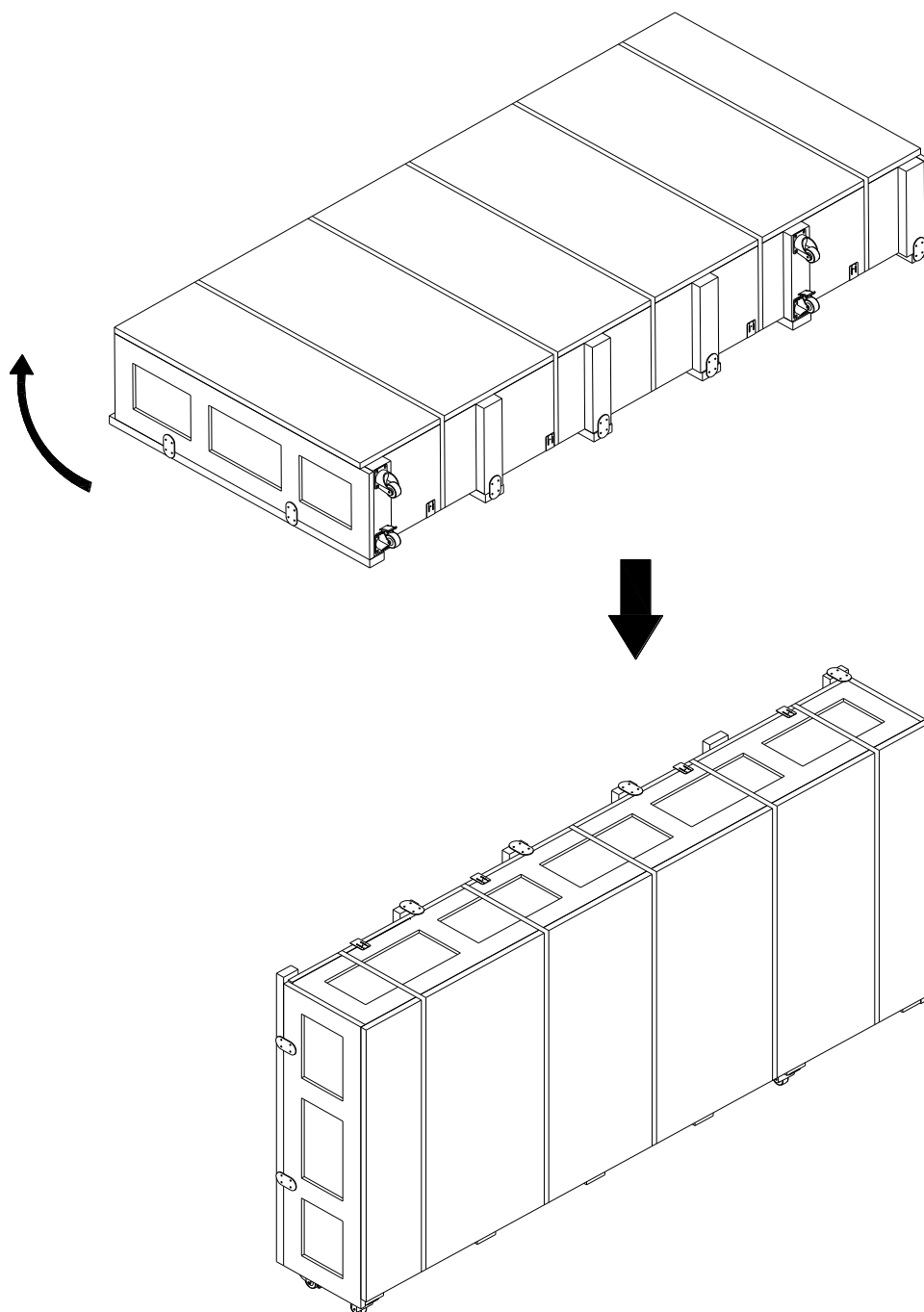

## STEP 2

You will find two transport wheels (E13) with brakes (E14) underneath the wooden case. The breaks must be released before moving the case.

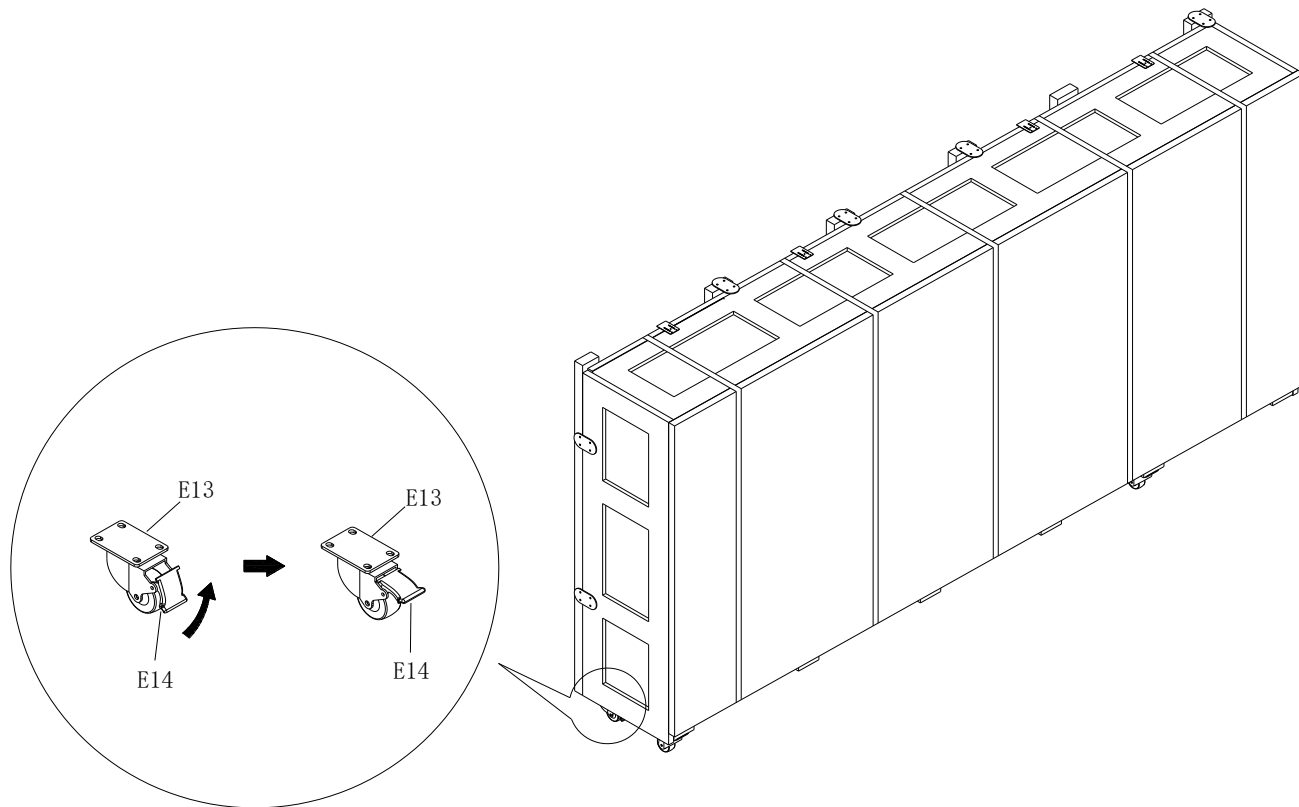

### STEP 3

After moving the case to the desired position, lay it down as per the illustration. Cut the strap (E15), and remove connecting pads (E16/E18) to remove the wooden case.

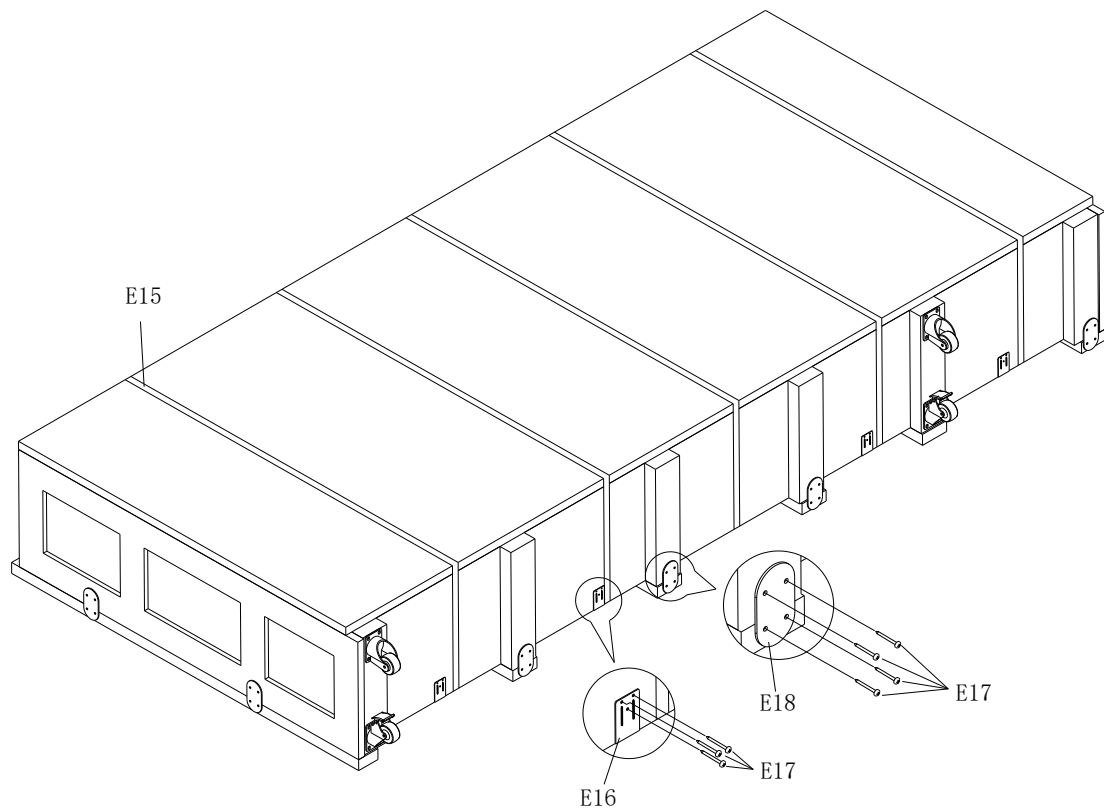



## STEP 4

Remove and save the fixing bracket (E2), nylon lock nut M8 (E4), transport wheel (E1) and round hex bolt M8\*85 (E3) from the wooden case.

Note: Save the transport wheels (E1/E13), fixing bracket (E2), nylon lock nut M8 (E4), round hex bolt M8\*85 (E3). These will be used to move the treadmill.

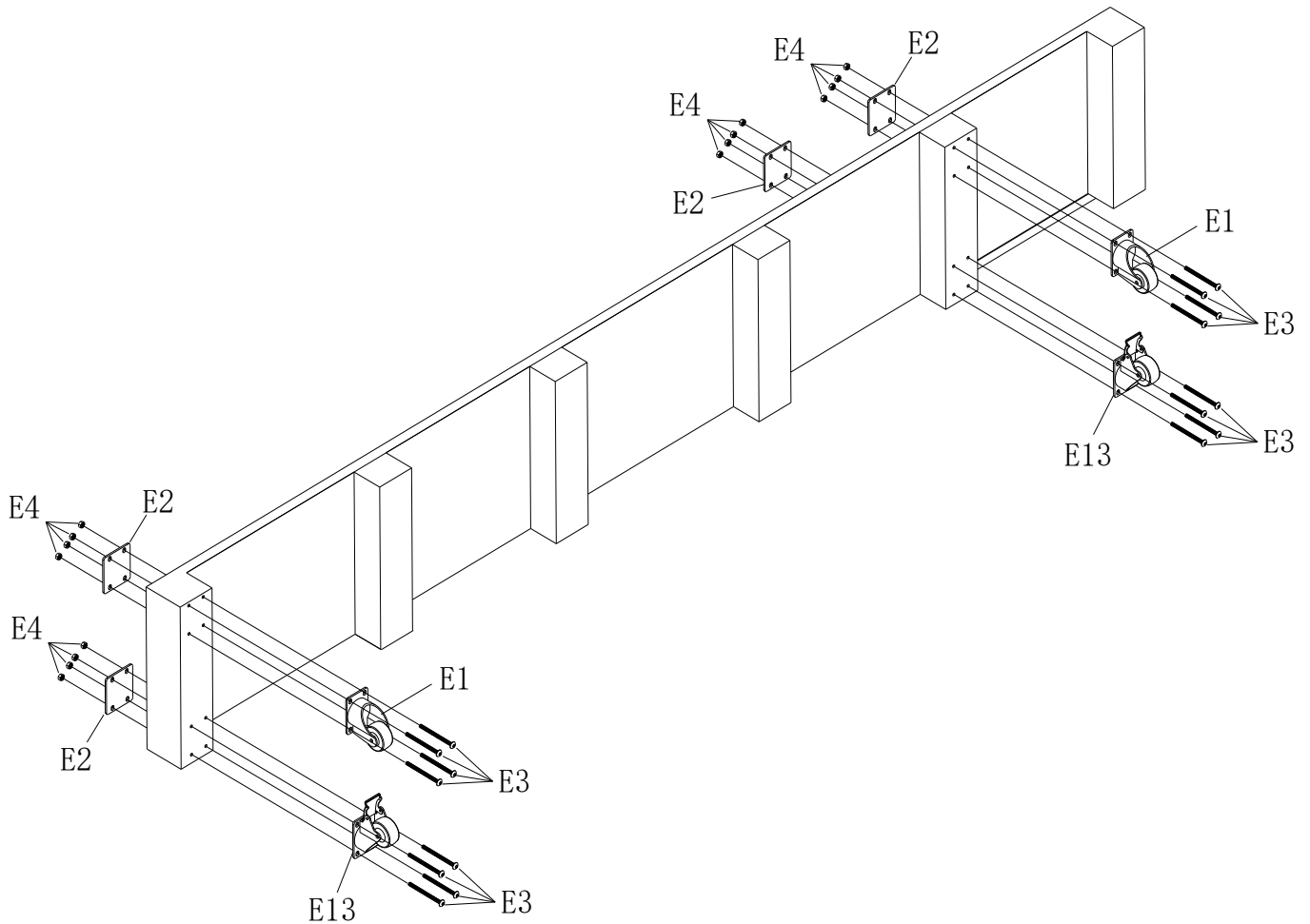

## STEP 5

Remove the hex round bolt M8\*40 (E7), hex round head bolt M8\*95 (E11), washer M8 (E8), flat washer M8 (E9) and nut M8 (E10) from upper/lower foot frame (E5/E6), and lift out the main frame.

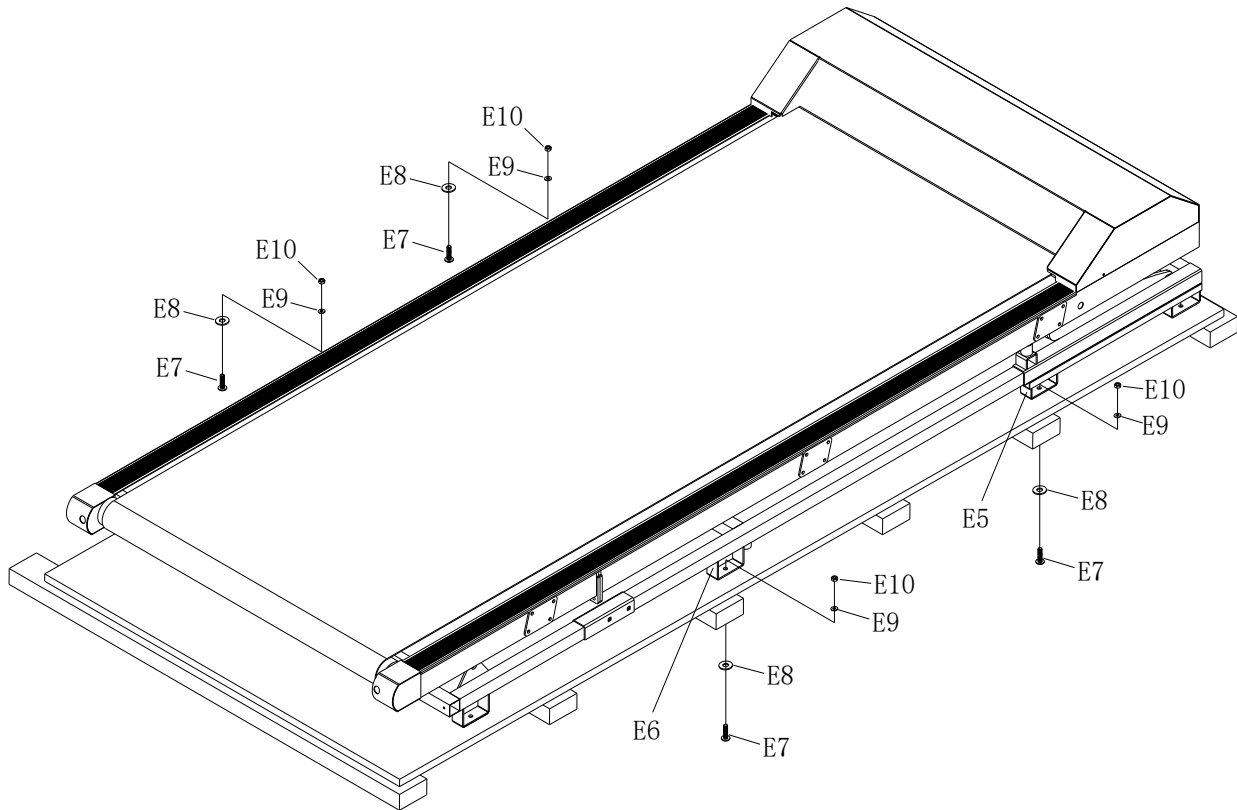

## STEP 6

Connect the left bar (A3L) to the main frame (A1a/b) using hex round head bolts M8\*20mm (D31), spring washers M8 (D25) and flat washers M8 (D23). Attach the right bar (A3R) to the main frame the same way. **Note: start all bolts before you tighten them.**

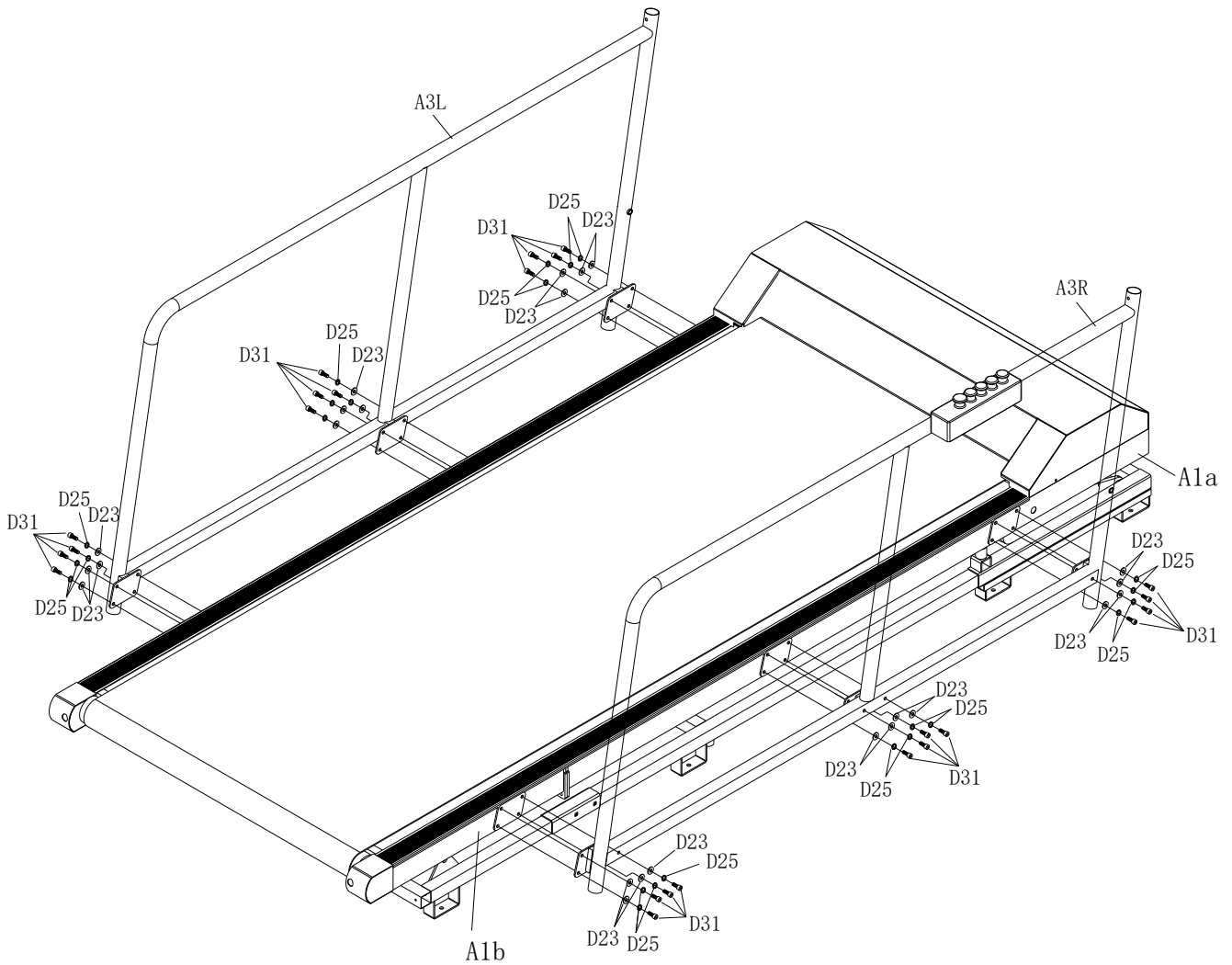

## STEP 7

Attach plugs (B2) to the bottom of left and right bars (A3L/R).

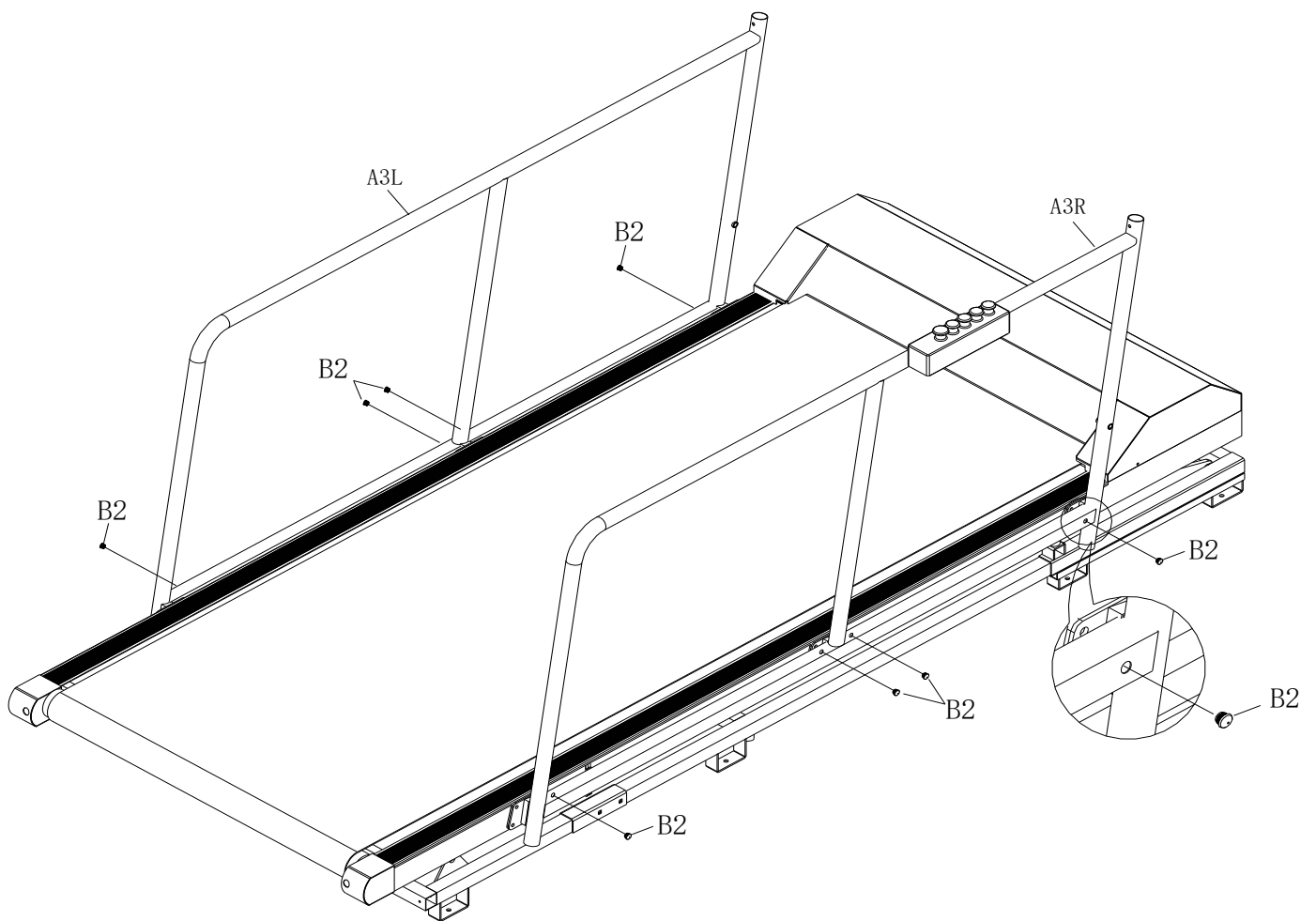

## STEP 8

Connect the lower wire's white connector (C17) to the middle wire's white connector (C18).

## STEP 9

Connect the quick switch's back wire's black connector (41) to the quick switch's middle wire's black connector (C42) and the middle wire's black connector (C18).

## STEP 10

Attach the front handrail (A4) to the left and right handrails (A3L/R) using hex bolt M8\*50mm (D6), small curved washer M8 (D66) and cap nut (D15).

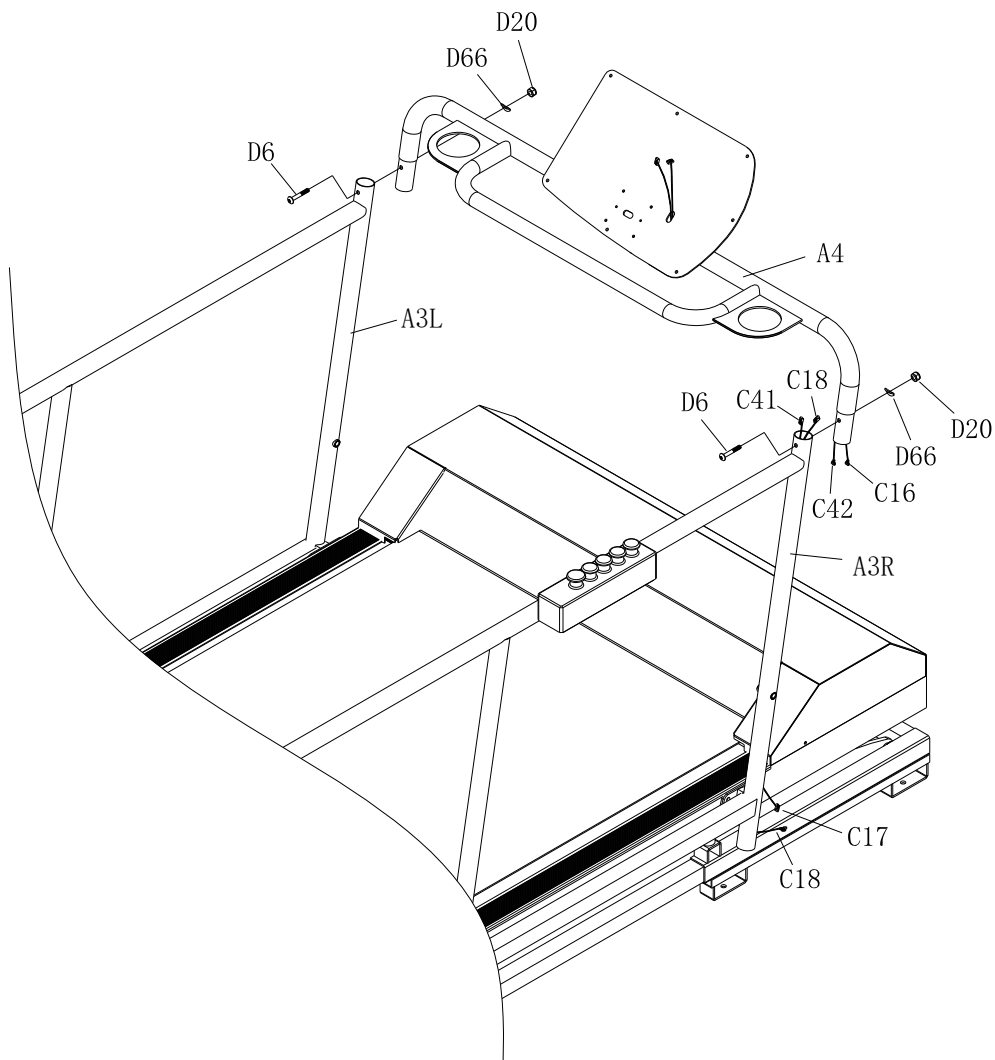

## STEP 11

Attach the 38 roller (C39) to left and right bar (A3L/R) using hex round head bolt M8\*60mm (D33), spring washer M8 (D25) and flat washer M8 (D23).

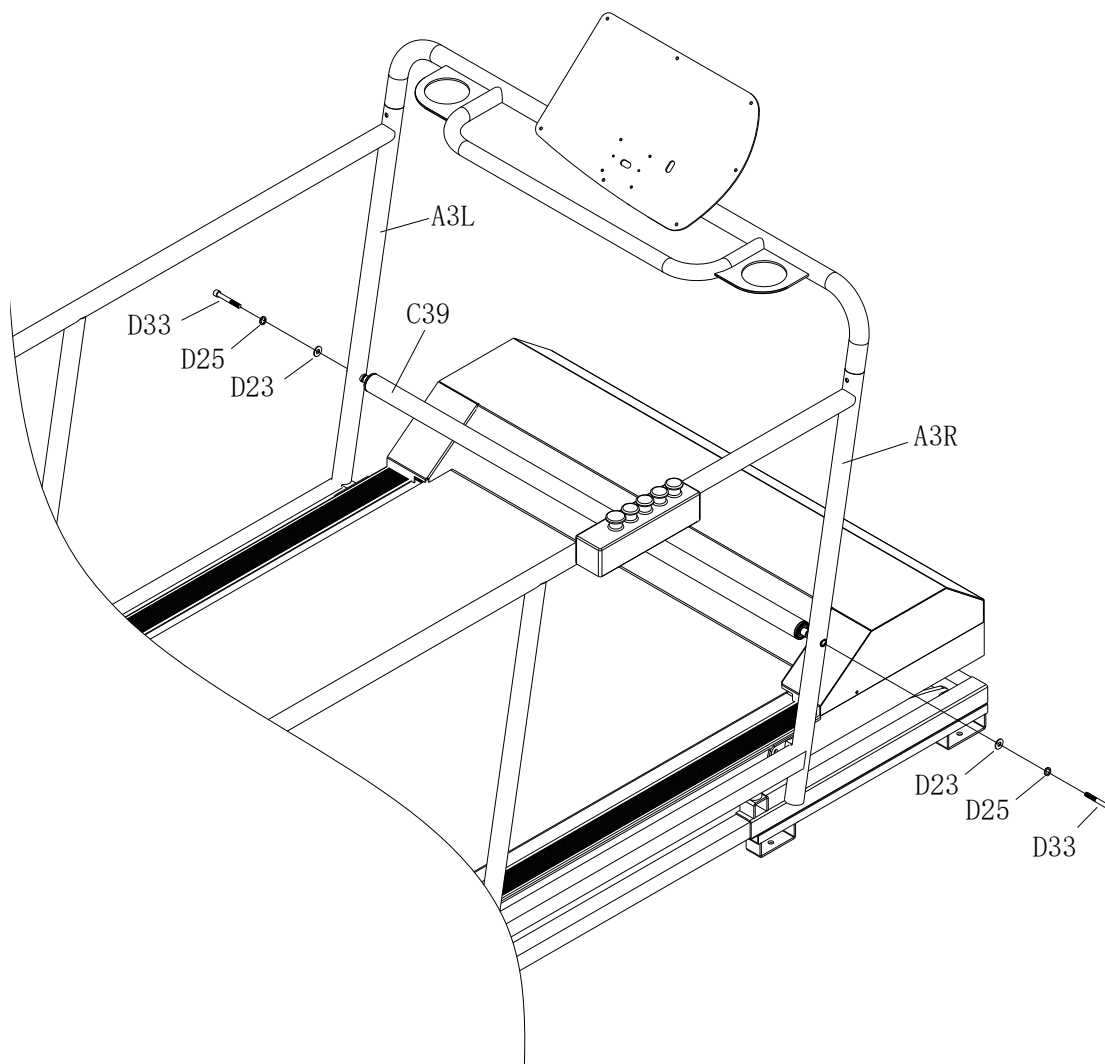

## STEP 12

Attach the iron fixing plate (A37) to the front handrail (A4) using round hex bolt M8\*20mm (D31) and large curved washer (D67).

## STEP 13

Guide the emergency switch's upper wire's black connector (C43) and the console's upper wire's white connector (C16) through the hole in the iron fixing plate (A11).

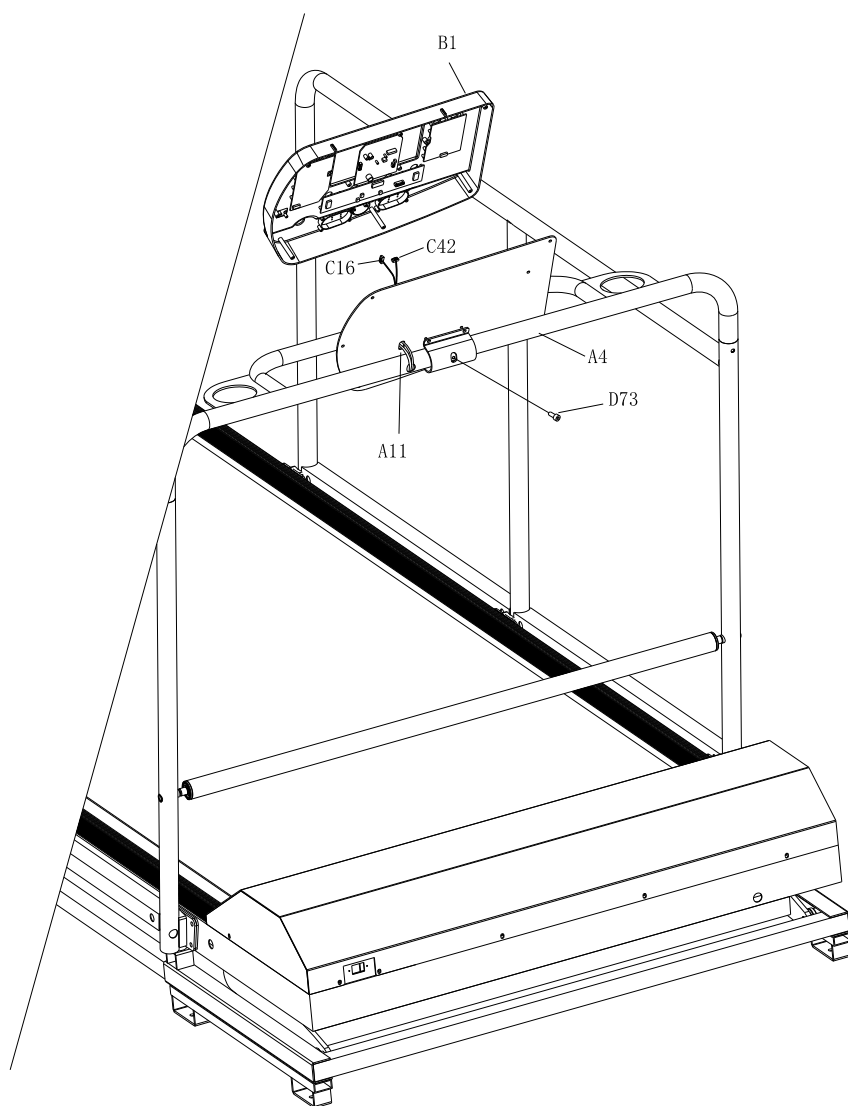

## STEP 14

Attach the console (B1) to the iron fixing plate (A11) using the cross bolt ST4.2\*16mm (D52).

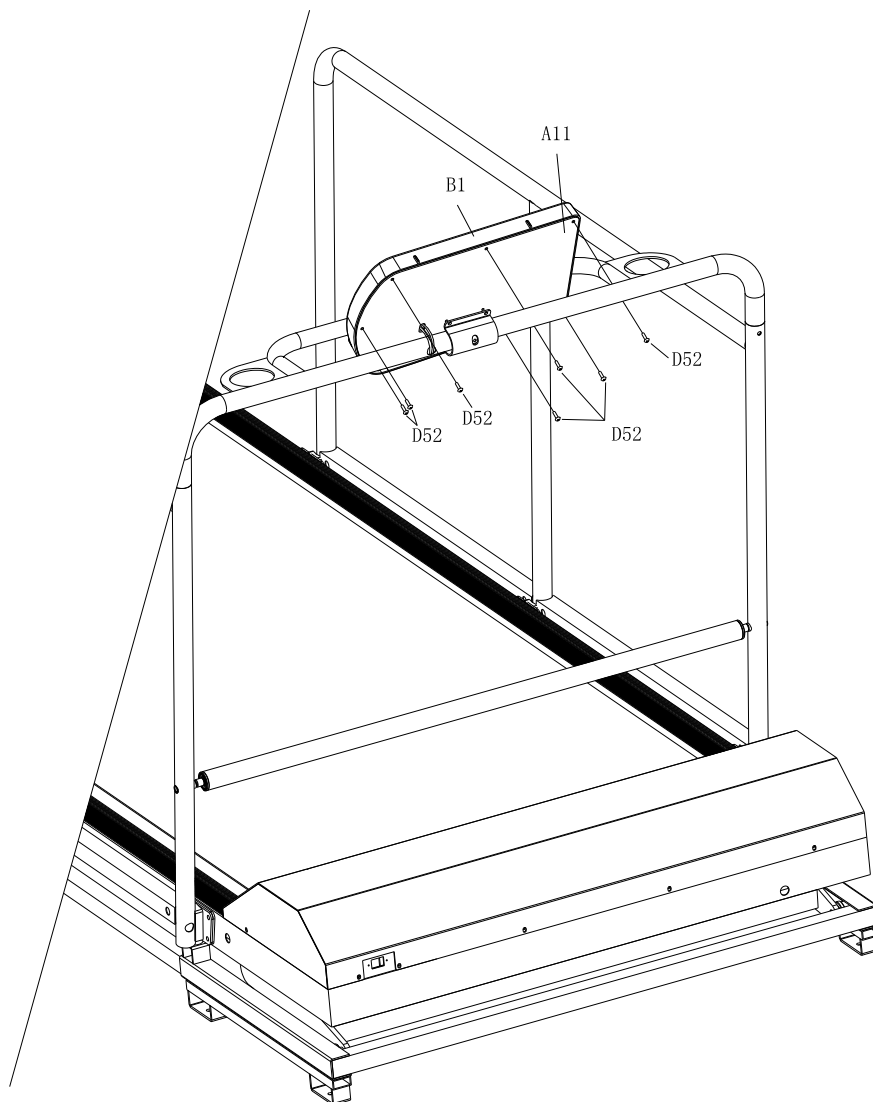



## STEP 15

Attach bottle holders (B16), safety key (C13) and power cable (C15).

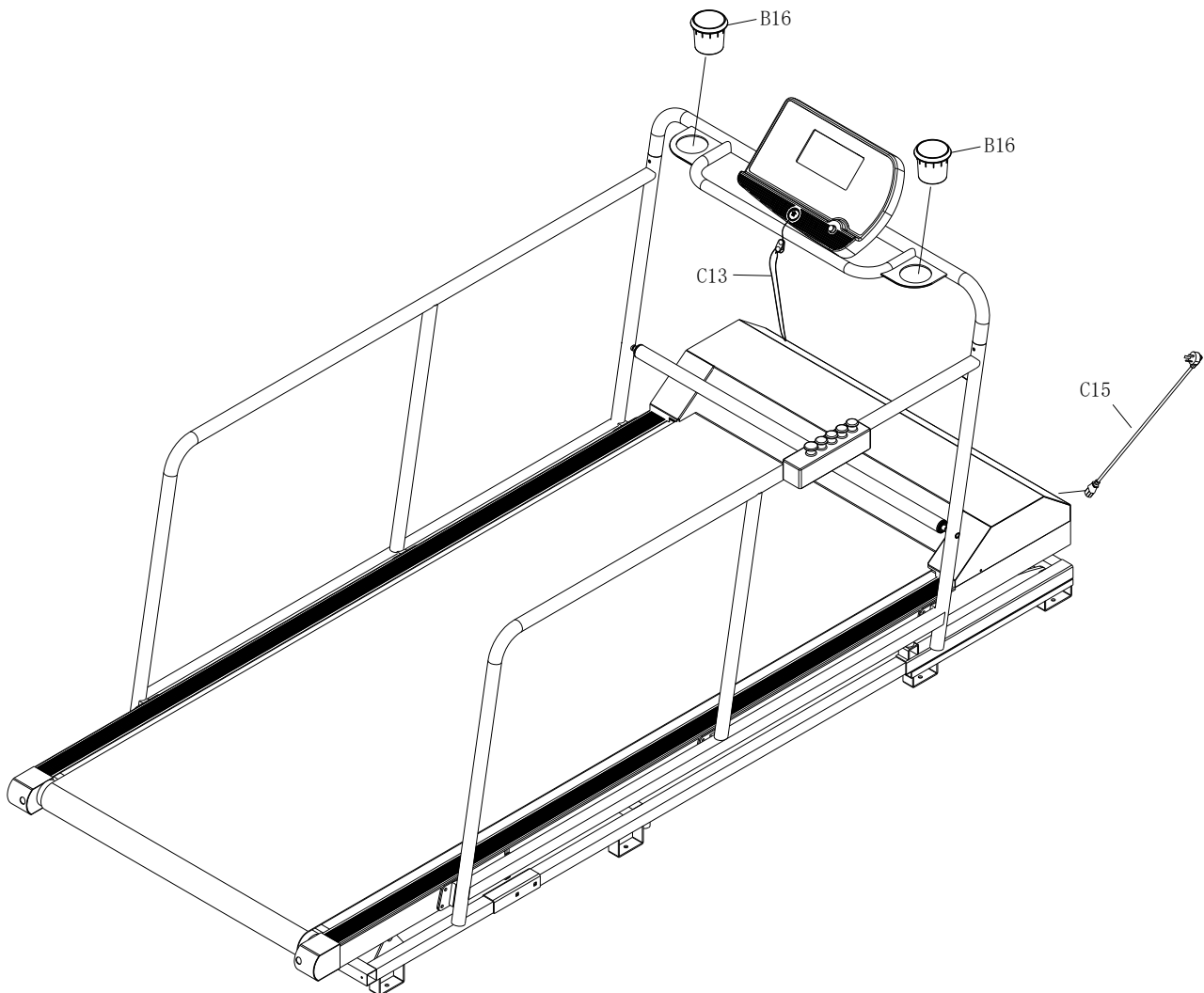

**Assembly is completed.**

# TREADMILL TRANSPORT WHEEL ASSEMBLY

## Transport wheel assembly:

Should you need to move the treadmill, it can be moved more easily by attaching the wheels that came with the wooden case. Place the fixing bracket (E2) onto upper and lower foot (E6/E5), and attach the transport wheels (E1/E13) to the fixing bracket using hex round head bolt M8\*20mm (E12) and nylon lock nut M8 (E4).

Push the treadmill to desired position, and remove the transport wheels. Alternatively, you can attach two wheels on the front of the treadmill, and lift the back.

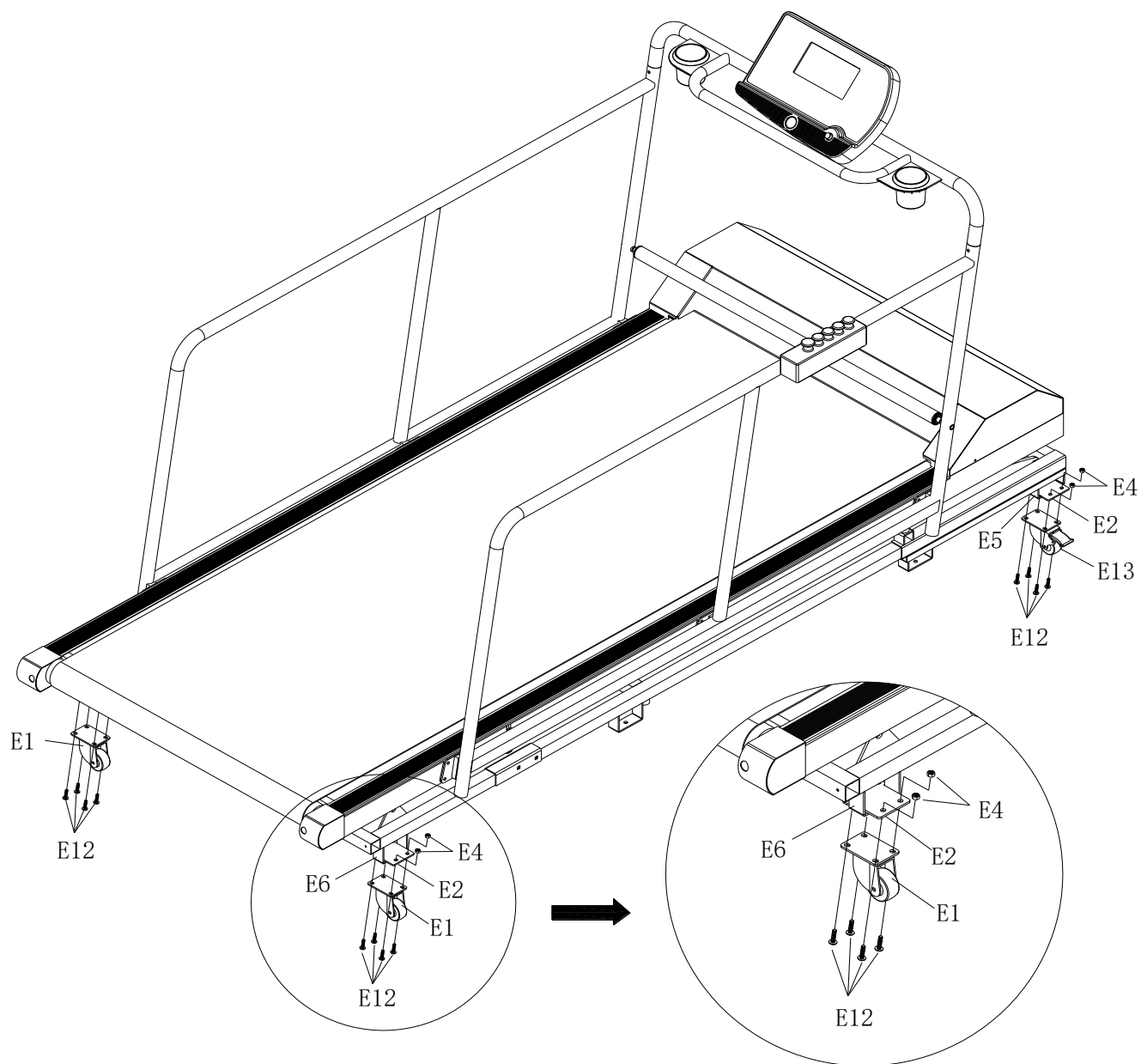

## THE TREADMILL MUST BE LUBRICATED BEFORE USE

### Lubrication

Apply 10 ml of the included oil on the sponge end of the included lubrication stick. Insert the stick underneath the running belt with the oily sponge facing down towards the wooden board. Start by the motor hood and run the stick in a zigzag pattern halfway down the deck. Apply another 10 ml of the included oil to the lubrication stick, and repeat the procedure. Then, set the running belt to move at a speed of 5 kph for five minutes.

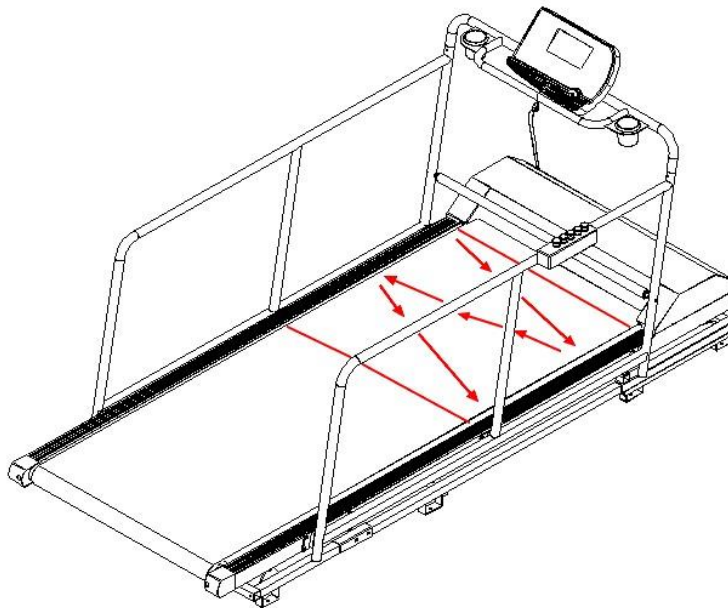

### Cleaning

After 100 hours of use, drag the lubrication stick underneath the running belt from top to bottom. Use the end of the stick that has *not* previously been used for oiling the running belt. Then, apply 10 ml of the included oil to the lubrication stick, and apply oil to the running belt as described above. Repeat for ever 100 hours of use. Should the treadmill stop on its own accord, it could be in need of lubrication.

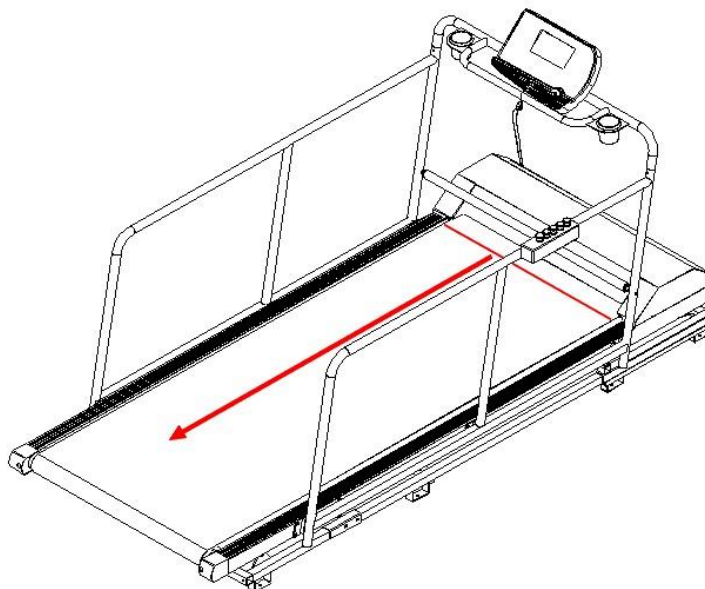

# CONSOLE POSITION CHANGE

## STEP 1

Remove the console (B1) and the adjustment guide (A12) by unscrewing the socket head cap bolt M8x20 (D31), large curved washer M8 (D67), Socket head cap bolt M6x16 (D5), flat washer M6 (D22), spring washer M6 (D11) as shown on the illustration.

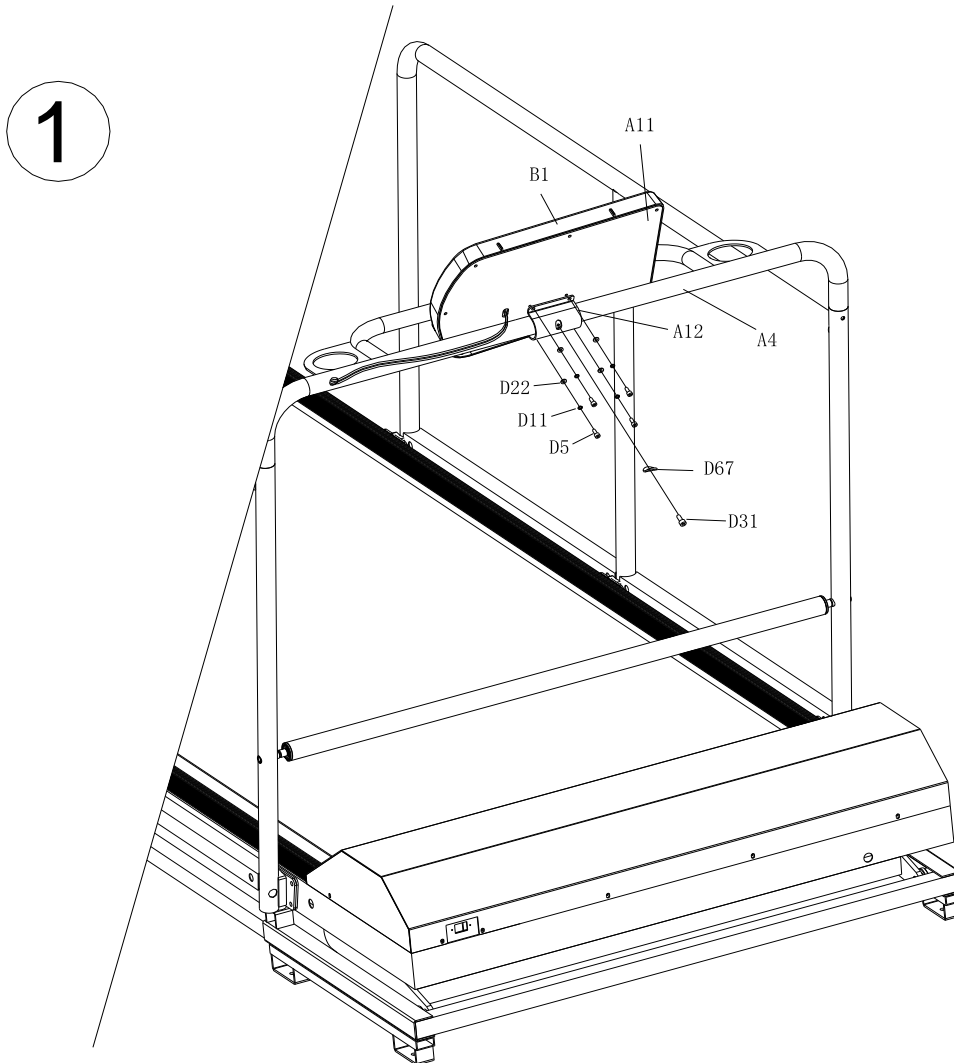

## STEP 2

Place the console (B1) and adjustment guide (A12) on the right handrail (A3R) and attach using socket head cap bolt M8x20 (D31), large curved washer M8 (D67), socket head cap bolt M6x16 (D5), flat washer M6 (D22) and spring washer M6 (D11) as shown on the illustration.

2

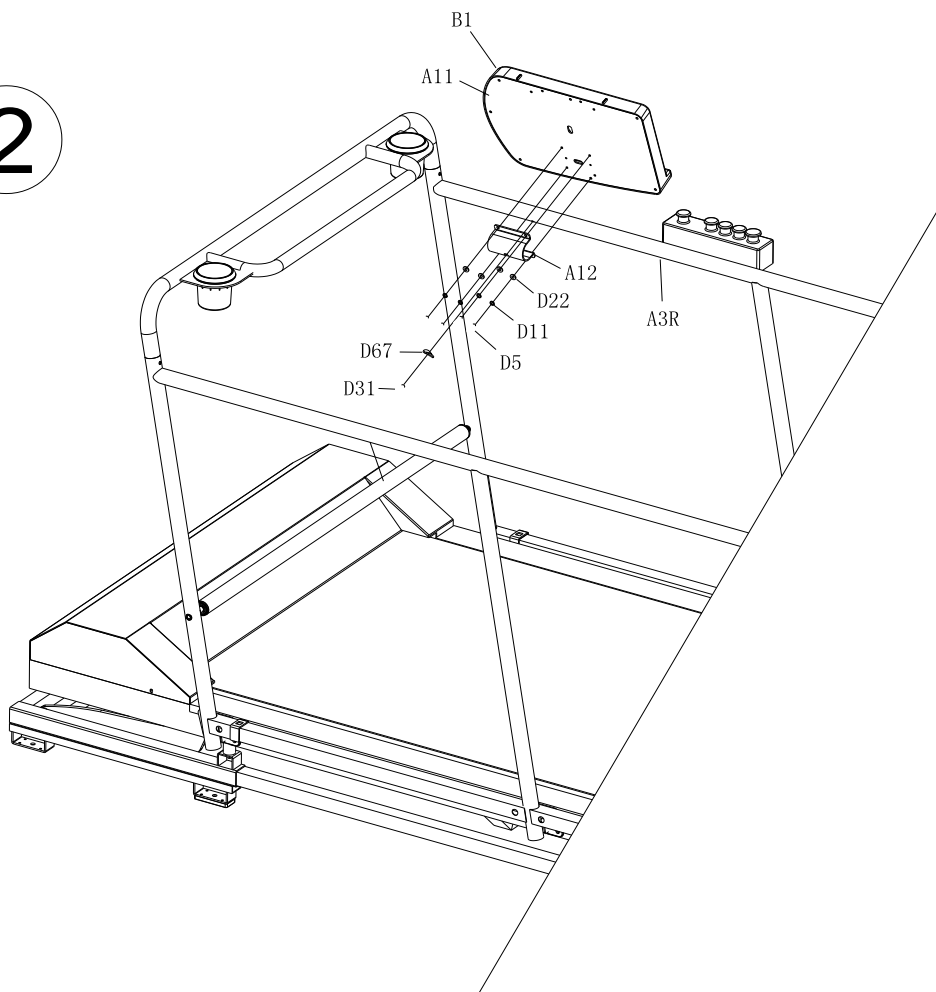

# CONSOLE

## 1.1 DISPLAY

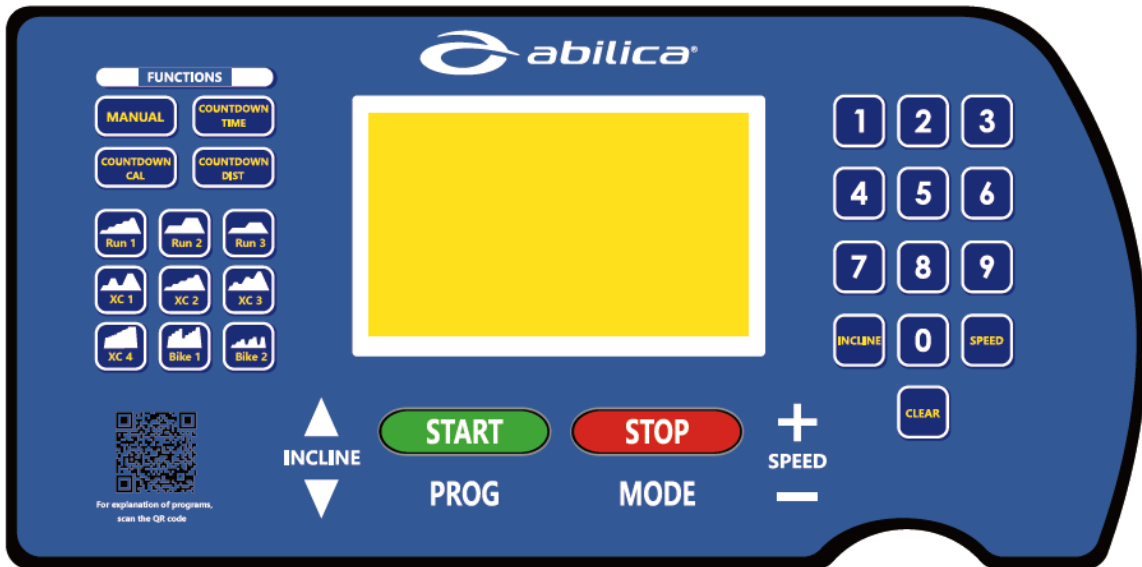

## 1.2. Start

Manual mode will start after a 5 second countdown.

## 1.3 Program

3 countdown modes / 9 pre-set programs / 3 modes / 3 user programs.

## 1.4. Safety key

Should the safety key be removed from the treadmill, the screen will show the message "----" before the console audio alerts and shuts down. Upon reconnecting the safety key, the screen will display all data for two seconds, and reset previous data.

## 1.5. BUTTON FUNCTIONS

START, STOP, PROG, MODE, SPEED/+/-, INCLINE/+/-, numbered buttons from 0 to 9, INCLINE CHECK, SPEED CHECK, CLEAR, P1 – P9, H1 –H3, and MANUAL.

### **1.5.1. Start/Stop**

“START” Push button to start running belt. Speed is set to 1.0.

“STOP” Push button to stop running belt.

### **1.5.2 Program**

Push button repeatedly to choose desired workout program. Choose between manual mode, pre-set programs P0 to P9, user programs U1 to U3, three countdown modes, or the fat burn program. Standard speed is set at 1.0 kph, and max speed is 30.0 kph. Incline starts at 0, and max incline is level 15.

### **1.5.3 Mode button**

Push button to choose countdown modes: H1 counts down time; H2 counts down distance; H3 counts down calories. Push SPEED +/- to adjust data. Push START to start running.

### **1.5.4 Speed +/-**

Push button to adjust speed at an increment of 0.5 kph. Hold button for more than two seconds to adjust speed quicker.

### **1.5.5 Incline +/-**

Push button to adjust incline at an increment of 1 level. Hold button for more than two seconds to adjust incline quicker.

### **1.5.6 Numbered buttons**

The numbered buttons can be used as quick buttons for both speed and incline. Push a number between 0 and 9 followed by either SPEED or INCLINE, to adjust the desired level.

### **1.5.7 Clear**

When pressing the wrong button, press CLEAR to delete the data.

### **1.5.8 Manual**

Push MANUAL to open HRC mode. You can choose HRC1, HRC2 or HRC3.

## **1.6. Display functions**

### **1.6.1 SPEED**

Displays running speed.

### **1.6.2 TIME**

Displays running time or how much time is left.

### **1.6.3 DISTANCE**

Displays total running distance, or how many kilometres are left.

### **1.6.4 CALORIE**

Displays calories burned, or how many calories are left to burn.

### **1.6.5 INCLINE**

Displays incline level.

### **1.6.6 PULSE**

Displays pulse data.

### **1.6.7 SPEED DIAGRAM**

Displays a diagram of the speed settings..

### **1.6.8 DATA RANGE**

TIME: 0:00 – 59:59 minutes (After one hour, 01:00 – 99:99 with flashing colon)

DISTANCE: 0.00 – 99.9 km

CALORIES: 0.0 – 999 kcal

SPEED: 1.0-30.0 kph

PULSE: 50 – 200 BPM

INCLINE: 0 – 15%

## **1.7 PULSE FUNCTION**

While the treadmill is running, hold the hand pulse sensors for about five seconds till the screen shows your pulse data. The pulse data range is 50 – 200 beats per minute (BPM). The heart symbol will flash when the console is reading your pulse. This data should only be used as a reference, and is not to be considered medical data.



## 1.8 PROGRAM EXERCISE CHART

TIME MODE		SET TIME / 16= EVERY GRADE TIME															
		1	2	3	4	5	6	7	8	9	10	11	12	13	14	15	16
P1 (16Min)	SPEED	10	10.5	11	11.5	12	12.5	13	13.5	14	14.5	15	15.5	16	16.5	17	17.5
	INCLINE	5%	5%	5%	5%	5%	5%	5%	5%	5%	5%	5%	5%	5%	5%	5%	5%
P2 (48Min)	SPEED	6.5	6.5	7.5	7.5	8.5	8.5	9.5	9.5	10	10	11	11	12	12	13	13
	INCLINE	10%	10%	10%	10%	10%	10%	10%	10%	10%	10%	10%	10%	10%	10%	10%	10%
P3 (48Min)	SPEED	8	8	9	9	10	10	11	11	12	12	13	13	14	14	15	15
	INCLINE	5%	5%	5%	5%	5%	5%	5%	5%	5%	5%	5%	5%	5%	5%	5%	5%
P4 (32Min)	SPEED	7	7	8	8	4	9	9	4	10	10	4	11	11	4	12	12
	INCLINE	12%	12%	12%	12%	12%	12%	12%	12%	12%	12%	12%	12%	12%	12%	12%	12%
P5 (16Min)	SPEED	8	8.5	9	9.5	10	10.5	11	11.5	12	12.5	13	13.5	14	14.5	15	15.5
	INCLINE	12%	12%	12%	12%	12%	12%	12%	12%	12%	12%	12%	12%	12%	12%	12%	12%
P6 (32Min)	SPEED	10	10	12	12	5	14	14	5	16	16	5	18	18	5	20	20
	INCLINE	4%	4%	4%	4%	4%	4%	4%	4%	4%	4%	4%	4%	4%	4%	4%	4%
P7 (16Min)	SPEED	14	14.5	15	15.5	16	16.5	17	17.5	18	18	18	18	18	18	18	18
	INCLINE	4%	4%	4%	4%	4%	4%	4%	4%	4%	4%	5%	5%	6%	6%	7%	7%
P8 (32Min)	SPEED	12	14	16	18	10	14	16	18	20	10	16	18	20	22	10	10
	INCLINE	8%	8%	8%	8%	8%	8%	8%	8%	8%	8%	8%	8%	8%	8%	8%	8%
P9 (32Min)	SPEED	7	9	10	7	10	11	7	11	12	7	12	13	7	13	14	7
	INCLINE	13%	13%	13%	13%	13%	13%	13%	13%	13%	13%	13%	13%	13%	13%	13%	13%

## 1.9 Manual mode

In addition to the 16 pre-set programs the console offers three user-defined programs: U1, U2 and U3. Each user program consists of 16 segments. The user can set the desired speed and incline for each segment.

1.9.1 Push SPEED +/- to adjust the speed on a scale from 1.0 to 24.0 kph.

1.9.2 Push INCLINE +/- to adjust the incline on a scale from 0 to 15.

1.9.3 Push MODE to save the first segment.

1.9.4 The next segment will start flashing. Repeat the process to adjust all segments.

1.9.5 Push STOP to return to the previous segment. You must complete all fifteen segments in order to use the program.

## 1.10 Countdown parametres

Standard value, time: 30:00 minutes  
Range: 5:00 – 99:00 minutes  
Step: 1:00

Standard value, calories: 50 therm  
Range: 10 – 990 therm  
Step: 10

Standard value, distance: 1.0 km  
Range: 0.5 – 99.9 km  
Step: 0.1

The screen will cycle through the data in the following order: MANUAL MODE, TIME, DISTANCE, CALORIES

## 1.11 Body tester (FAT)

After switching on the console, push the PROGRAM button repeatedly to enter the FAT body test. Push MODE to enter values for GENDER (F1), AGE (F2), HEIGHT (F3) and WEIGHT (F4). Push SPEED(+) or SPEED(-) to set the values. After all values are set, the console will display the message F5. Grasp the hand pulse sensors. The screen will now display your body quality index.

The body quality index represents the relation between your height and weight. The ideal score should be between 20 and 25. Below 19 means that you are underweight. Between 25 and 29 means that you are overweight. Above 30 means that you are obese.

01	Gender	01-Male 02-Female
02	Age	10-99
03	Height	100-220
04	Weight	20-150
05	FAT ≤19	Underweight
	FAT = (20-25)	Normal weight
	FAT = (25-29)	Overweight
	FAT ≥30	Obese

## **1.12 Others**

**1.12.1** When the countdown is over, the message END will be shown on the display. The console will then audibly alert you before the treadmill stops. The manual mode will then automatically be selected.

**1.12.2** If you choose values from a set range, you can proceed from the highest value back to the lowest by pushing (+). Likewise you can proceed from the lowest value to the highest by pushing (-). For example, if you set a value on a scale from 5:00 to 99:00, and have chosen 99:00, you can push (+) to immediately return to 5:00.

**1.12.3** You can only set one countdown value per workout.

**1.12.4** Speed control: Acceleration: 0.5 km/sec; braking: 0.5 km/sec.

## **1.13 Buttons**

### **1.13.1 INCLINE (+)(-)**

Push INCLINE (+)(-) to adjust incline while the running belt is moving. Increment is 1 level per button push.

### **1.13.2 SPEED (+)(-)**

Push SPEED (+)(-) to adjust speed while the running belt is moving. Increment is 0.5 kph per button push.

### **1.13.3 STOP**

In an emergency, push the STOP button to stop the running belt.

## Programs

### Note:

All programs are installed to start interval from LEVEL 1 (Grade time). This means that warm-up and cool-down is not included in the main program, and that it is the user's own responsibility to adjust proper warm-ups and cool-downs in manual mode.

### **RUN1 – RUN VO2 MAX**

Performance test run for measuring Vo2 max and capacity. The program is carried out constantly on a 5% incline with an increase of 0.5 kph per minute, as a step test. Output speed of 10 kph. With this test, you can easily measure your capacity by seeing how many loads you are able to perform from workout to workout. With equipment for measuring maximum oxygen uptake, you can use this during the execution of the test.

### **RUN2 – RUN – LACTATE PROFILE**

Lactate profile test run for measuring anaerobic threshold and work economy. The program is carried out constantly on a 10% incline with a pull of 6 minutes per load. Output speed of 6.6 kph. With this test, you can easily measure your anaerobic threshold and work economy by seeing when the lactate exceeds anaerobic values (+ - 3.5 goals with lactate scout pro). You can also estimate your oxygen uptake by assuming that oxygen uptake increases linearly with load. (Example: 6.6 km corresponds to 32-33 Vo2, 10.2 kph corresponds to 55-56 vo2, 12 ph corresponds to 65 Vo2 etc).

### **RUN3 – RUN – LACTATE PROFILE**

Lactate profile test run for measuring anaerobic threshold and work economy. The program is carried out constantly on a 5% incline with a pull of 6 minutes per load. Output speed of 8 kph. With this test, you can easily measure your anaerobic threshold and work economy by seeing when the lactate exceeds anaerobic values (+ - 3.5 goals with lactate scout pro). You can also estimate your oxygen uptake by assuming that oxygen uptake increases linearly with load. (Ex: 8 km corresponds to 32-33 Vo2, 12 kph corresponds to 55-56 vo2, 15 kph corresponds to 65 Vo2 etc)

### **XCD1 – DIAGONAL INTERVAL PROFILE**

Progressive interval training for diagonal training on roller skis. 8 min pull, 2 min pause, 4 min pull, 2 min pause, 4 min pull, 2 min pause, 4 min pull, 2 min pause, 4 min pull, 2 min pause. The pulls are carried out on a 12% incline. The breaks are carried out in the same incline with a light load (speed). Efficient program for exercising downhill capacity on roller skis and technique in diagonal walking.

### **XCD2 – DIAGONAL – PRESTASJONSTEST**

Performance test roller ski for measuring capacity and performance uphill. The program is carried out constantly at a 12% incline with an increase of 0.5 kph per minute, as a step test. Output speed of 8 kph. With this test, you can easily measure your capacity by seeing how many loads you are able to perform from workout to workout. With equipment for measuring maximum oxygen uptake, you can use this during the execution of the test. In addition, you can efficiently work with technique on increasing load and adapt in relation to speed.

### **XCDP1 – POLING INTERVAL – PROFILE**

Progressive interval training for poling on roller skis. 8 min pull, 2 min pause, 4 min pull, 2 min pause, 4 min pull, 2 min pause, 4 min pull, 2 min pause, 4 min pull, 2 min pause, 4 min pull, 2 min pause. The pulls are carried out at a 4% incline. The breaks are carried out in the same incline with a light load (speed). Efficient program for training technique and pole capacity in gentle uphill terrain on roller skis. With such a progressive interval workout, you will achieve a good execution of the session that will ensure you great benefits both technically and physically.

### **XCDP2 – POLING – PERFORMANCE TEST**

Performance test roller ski for measuring capacity and performance in poling gently uphill. The program is carried out constantly at a 4% incline with an increase of 0.5 kph per minute, as a step test up to 10 minutes. Output speed of 14 kph. After 10 minutes, the speed is 18 kph and the program then increases with 1% every 2 minutes. 10-12min 5%, 12-14min 6% and 14-16min 7%. With this test, you can easily measure your capacity by seeing how many loads you are able to perform from workout to workout. With equipment for measuring lactate or maximum oxygen uptake, you can use this during the test. In addition, you can efficiently work with technique on increasing load and adapt in relation to speed.

### **BIKE1 – BIKE – MODERATE HILL**

Interval program bicycle at a moderate incline for the development of uphill capacity. The program is carried out constantly at a 8% incline at 8 minute intervals with progressive increase in speed every 2 minutes. Pull 1 has an output speed of 12 kph - increased to 14 kph after 2min - increased to 16 kph after 4 min – 18 kph after 6 min. After 8min, the speed is reduced to 10 kph and you get an active break of 2 min before the next pull. The next pulls are carried out in the same way as the previous ones with an output speed of 14 and 16 kph, respectively, with the same progression with an increase of 2 kph per 2 minutes - active break for 10 kph of 2 min after each 8min pull. In total, the program gives you a 3x8 minute interval in a moderate incline.

### **BIKE2 – BIKE – STEEP UPHILL**

Interval program bicycle on steep inclines for the development of uphill capacity. The program is carried out constantly at a 13% incline in 4 minute intervals with progressive increase in speed every 2 minutes. Pull 1 has an output speed of 9 kph - increased to 10 kph after 2min. After 4min, the speed is reduced to 7 kph and you get an active break of 2 min before the next pull. The next pulls are carried out in the same way as the previous ones with an output speed of 10, 11, 12 and 13 kph, respectively, with the same progression with an increase of 1 kph per 2 minutes. - active break for 7 kph of 2 min after each 4min pull. In total, the program gives you a 5x4 minute interval in steep incline.

## Electrical safety

If an overvoltage has occurred, the blue square button (1) will pop out and the power switch (2) will turn off. The blue button must be pressed before you can turn on the power switch again.

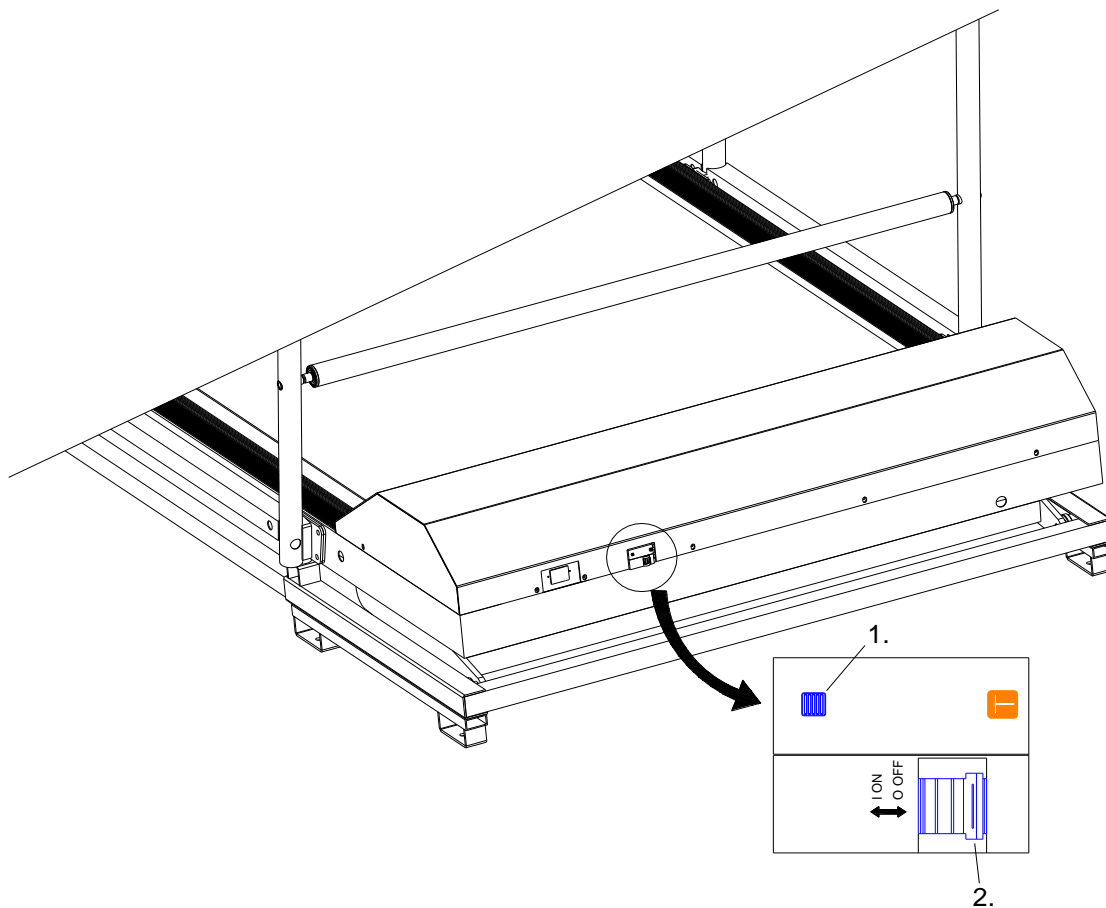

## MAINTENANCE

### NOTE:

Make sure the electrical outlet is unplugged before cleaning and / or maintaining the product.

### CLEAN:

Regular cleaning will extend the lifespan of the product. Clean the appliance by keeping it free of dust. Be sure to wash the visible parts of the platform on each side of the treadmill, and on the foot rails. This reduces the accumulation of dust and foreign particles under the treadmill. Make sure you wear clean running shoes when using the device. The outside of the treadmill can be cleaned with a wet soapy cloth. Be sure to keep the liquid away from the inside of the treadmill frame and beneath of the treadmill.

### NOTE:

Always unplug the power cord before removing the motor hood. You should remove the hood and vacuum the motor at least once a year.

The treadmill and platform are pre-lubricated. The friction in the treadmill and platform can play a major role in the lifespan of your product, and you should therefore lubricate these parts regularly to maintain the device in the best possible condition. It is recommended that you periodically inspect the platform.

### Recommended inspection plan:

The device is used less than 3 hours per week: 60 days

The device is used 3 – 5 times per week: 45 days

The device is used 5 hours or more per week: 30 days

OR

that after every 80 hours of use you use a lubricant as described on the following two pages. See last page for contact information if you have questions about lubrication. Contact customer service if you need other maintenance.

<b>Part</b>	<b>Recommended maintenance</b>	<b>How often?</b>	<b>Cleaning</b>	<b>Lubrication</b>
Display	Clean with a soft, clean and moist cloth.	After use	No	No
Frame	Clean with a soft, clean and moist cloth.	After use	Water	No
Running belt	Clean with a soft, clean and moist cloth.	Weekly	No	No
Running deck	Clean with a soft, clean and moist cloth. Make sure that it has sufficient applied lubricant and the surface is smooth.	Weekly	No	Yes*
Drive belt	Inspect that the drive belt is sufficiently tight, check for any wear and that drivebelt is in the correct position.	Monthly	No	No
Bolts, nuts etc.	Inspect all bolts, nuts and screws. Tighten if necessary.	Monthly	No	No

\* Always use the manufacturer's recommended lubricant



## SAFETY PRECAUTIONS

1. Position the treadmill on a clear and level surface. Do not place the treadmill on thick carpet as it may interfere with proper ventilation. Also, do not place the treadmill near water or outdoors.
2. Keep young children or pet away from the treadmill during operation.
3. The treadmill is only used for adults. Children must have supervision from adult if using the treadmill.
4. EMERGENCY DISMOUNT: In case you must leave the equipment in an EMERGENCY SITUATION, grab the handrail and set both feet on the right and left foot platform beside the running belt. Now you pull out the safety switch, in order to slow down the equipment
5. Function of the safety stop: If you would like to stop the equipment, then you can stop it either with the STOP switch on the console or pull out the, SAFETY KEY from the console. If you pull the SAFETY KEY from the console, this case the computer shut down all functions automatically and the running belt slow down and come to a stop immediately.
6. The treadmill is for home & Club used.
7. When setting up your treadmill, Behind the equipment when in use. and remember to keep a safety area clear at least 2000mm behind the treadmill and 600mm to the other three sides of the treadmill, as below graph.
8. Maximum allowed running surface lateral position is 25mm.
9. The value of the A-weighted emission sound pressure is 72dB for reference.
10. Noise emission under load is higher than without load.
11. Importer: MYLNA SPORT & FITNESS
12. Address of Importer: PO 244, ORKIDEHOGDA, NO-3051, MJONDALEN NORWAY

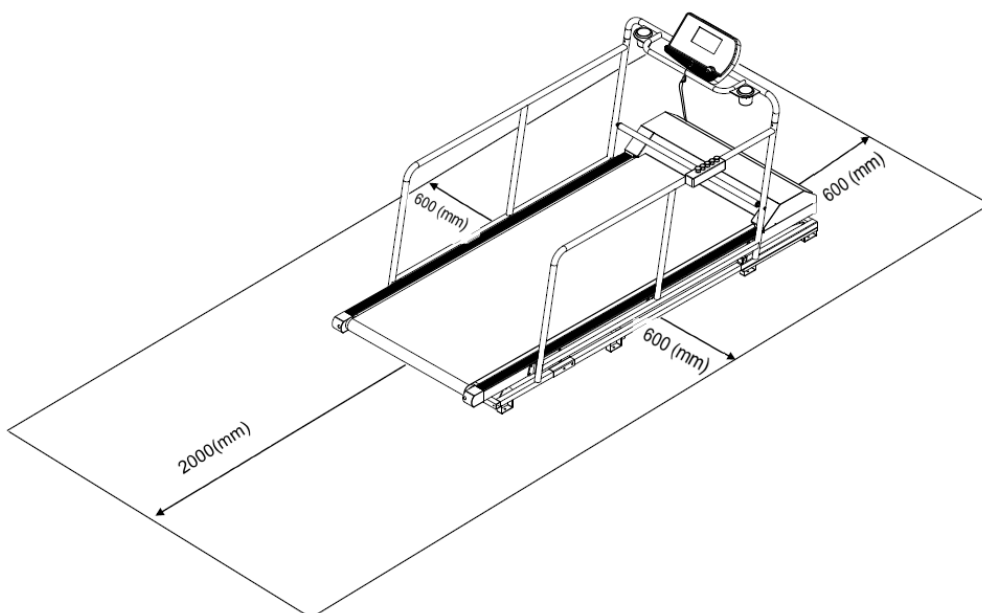

## Belt Adjustment

Place treadmill on a level surface. Make treadmill run at approximately 6-8 km/h, observe the running belt deviate condition.

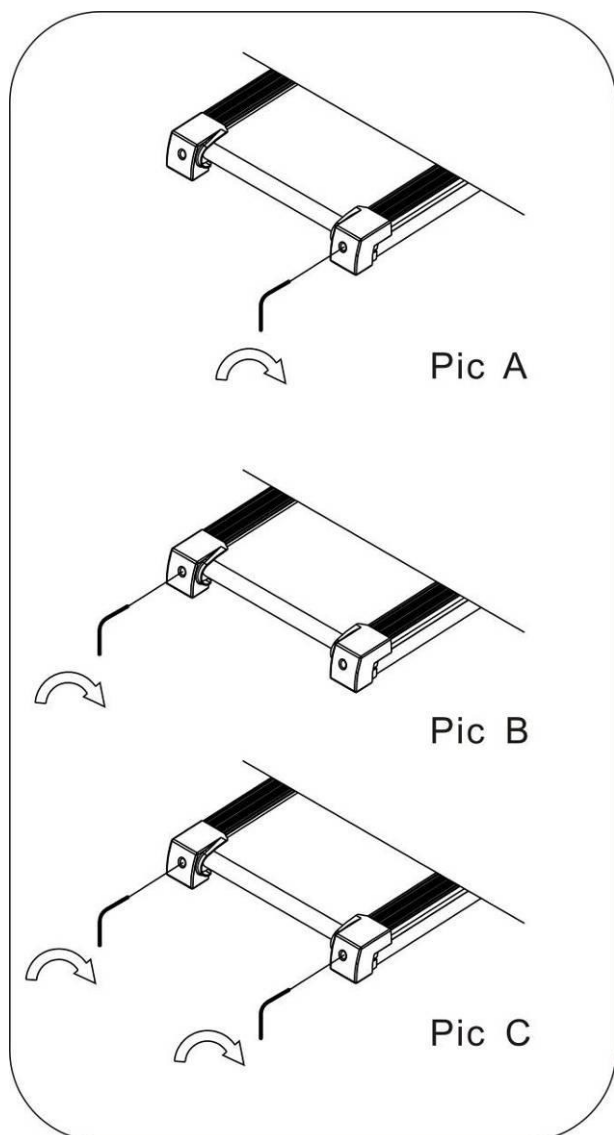

If the belt has drifted to the right, unplug the safety lock and power switch, and turn the right adjusting bolt 1/4 turn clockwise, then insert the power switch and safety lock, make the treadmill running, observe the running belt deviate condition. Repeat above steps until the running belt be placed in the middle. **See picture A**

Once the treadmill belt swerving to the left, unplug the safety lock, turn off the power, then with the left adjusting bolt clockwise rotation 1 / 4 laps, and turn on the safety lock and power to make treadmill running, checking the deviation of the treadmill belt. Repeat the above steps until the belt centered. **See picture B**

The treadmill belt will gradually relax after above steps or after a period of time using, unplug the safety lock, and turn off the power, with the two adjusting bolt clockwise rotation 1 / 4 laps, and turn on the safety lock and power to make treadmill running, then standing on the belt to confirm the tightness. Repeat the above steps until the belt moderate tightness. **See picture C**

# EXPLODED DRAWING

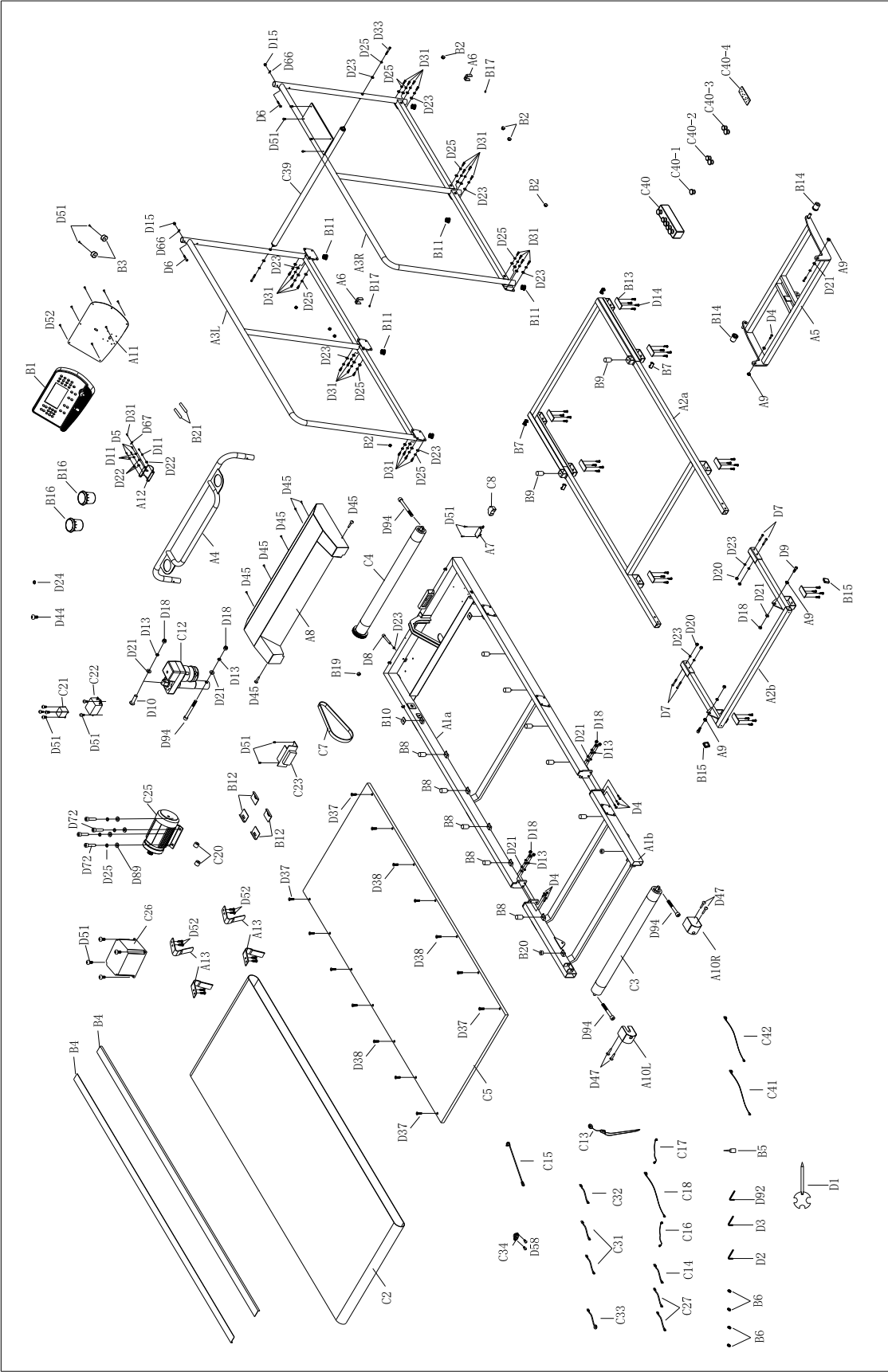

# PART LIST

## A. Welded parts

NO.	Description	Qty		NO.	Description	Qty
A1a	Front Base Frame	1		A7	L-shaped tablet	1
A1b	Back Base Frame	1		A8	Motor Upper Cover	1
A2a	Front Main Frame	1		A9	Incline Shaft	4
A2b	Back Main Frame	1		A10L	Left End Cap	1
A3L	Left Handrail	1		A10R	Right End Cap	1
A3R	Right Handrail	1		A11	Iron Fixed Plate	1
A4	Front Handrail	1		A12	Adjustment Guide	1
A5	Incline Frame	1		A13	Belt Guide	4
A6	Slider Bracket	2				

## B. Plastic parts

NO.	Description	Qty		NO.	Description	Qty
B1	Console Set	1		B10	Rubber Pad	2
B1-1	Overlay	1		B11	Round Inner Plug $\phi$ 38	6
B1-2	Membrane Key	1		B12	L-Shaped Side Rail	4
B1-3	Console Panel	1		B13	Non-Slip Rubber Pad	8
B2	Round Inner Plug $\phi$ 19	8		B14	Incline roller	2
B3	Limiting Cushion	2		B15	Square Inner Plug 38*38	2
B4	Side Rail	2		B16	Water Bottle	2
B5	Silicon Oil	1		B17	Magnet	2
B6	Round Plug	4				
B7	Square Inner Plug 20*40	4		B19	Round Plug $\phi$ 22	1
B8	New Cushion	10		B20	Running Board Cushion	2
B9	Limiting Cushion M8*15 mm	2		B21	EVA Pad	2

## C. Electrical parts

NO.	Description	Qty	NO.	Description	Qty
C2	Running Belt	1	C23	Brake	1
C3	Rear Roller	1	C25	AC Motor	1
C4	Front Roller	1	C26	Inverter	1
C5	Running Board	1	C27	Single Cord (Blue) 300	2
C7	Motor Belt	1	C31	Single Cord (Brown) 150	2
C8	Power switch	1	C32	Single Cord (Blue) 150	1
C12	Incline Motor	1	C33	Single Cord	1
C13	Safety Key	1	C34	Outlet	1
C14	Single Cord (Brown) 300	1	C39	38 Roller set	1
C15	Power Cable	1	C40	Quick Switch (Set)	1
C16	Console Upper Cable-White plug	1	C40-1	Emergency Stop Button	1
C17	Console Lower Cable-White plug	1	C40-2	Incline Button (Green)	2
C18	Middle Cable -White plug	1	C40-3	Speed Button (Red)	2
C20	Magnetic Ring	2	C40-4	Quick Button PCB Board	1
C21	Inductor	1	C41	Quick switch Lower Cable-Black plug	1
C22	Filter	1	C42	Quick switch Upper Cable-Black plug	1

## D. Hardware

NO.	Description	Qty	NO.	Description	Qty
D1	Screw Driver/Wrench 13-15-17	1	D24	Spring Washer M5	1
D2	Allen Wrench T6	1	D25	Spring Washer M8	30
D3	Allen Wrench T5	1	D31	Socket Head Cap Bolt M8X20	25
D4	Socket Head Cap Bolt M10X35	8	D33	Socket Head Cap Bolt M8X60	2
D5	Socket Head Cap Bolt M6X16	4	D37	Countersunk Head Hex Bolt M6X35	4
D6	Round Head Hex Bolt M8X50	2	D38	Countersunk Head Hex Bolt M6X30	10
D7	Round Head Hex Bolt M8X60	4	D44	Cross Washer Head Bolt M5X12	1
D8	Socket Head Cap Bolt M8X60	1	D45	Cross Washer Head Bolt M5X15	7
D9	Socket Head Cap Bolt M10X30	2	D47	Cross Washer Head Self-drilling Tapping Bolt ST4.2X16	4
D10	Round Head Hex Bolt M10X45	1	D51	Cross Pan Head Bolt M5X8	20
D11	Spring Washer M6	4	D52	Cross Pan Head Tapping Bolt ST4.2X16	15
			D58	Cross Countersunk Head Self-drilling Tapping Bolt ST3.5X16	2
D13	弹簧垫圈 M10	8	D66	Small Curved Washer M8	2
D14	Cross Pan Head Bolt M6x12	32	D67	Large Curved Washer M8	1
D15	Cap Nut	2	D72	Socket Head Cap Bolt M8X25	4
D18	Nylon Nut M10	10			
D20	Nylon Nut M8	6	D89	Large flat washer M8	4
D21	Flat washer M10	12	D92	Allen Wrench T8	1
D22	Flat washer M6	4	D94	Socket Head Cap Bolt M10X70	4
D23	Flat washer M8	31			

# Error codes

Error Code	Description	Solutions
E1	Communication error between Inverter and console	<ol style="list-style-type: none"> <li>1. Check if computer is connected to inverter with correct wires, check connector, check if wire is damaged, or unplug and re-connect</li> <li>2. Replace inverter and test</li> <li>3. Replace computer and test</li> </ol>
E2	Inverter too hot	<ol style="list-style-type: none"> <li>1. Switch off for over 20 seconds and switch on again.</li> <li>2. Check if the fan and heat sink are clean or if the fan is working.</li> <li>3. Replace inverter.</li> </ol>
E3	Low input voltage	<ol style="list-style-type: none"> <li>1. Switch off for over 20 seconds and switch on again.</li> <li>2. Check if the input voltage low.</li> <li>3. Replace inverter.</li> </ol>
E4	Incline adjustment	<ol style="list-style-type: none"> <li>1. Check incline motor sensor wire if connect well, re-plug in.</li> <li>2. Check incline motor AC cable if connect correct, the incline AC cable is connect correct to follow the controller mark.</li> <li>3. Check if the cable of motor is damage.</li> <li>4. Replace cable or incline motor, then press the adjustment button to running again.</li> </ol>
E5	Overvoltage, Inverter	<ol style="list-style-type: none"> <li>1. Skru av i 20 sekunder, og skru på igjen.</li> <li>2. Forsikre deg om at valsene beveger seg uhindret. Forsikre deg om at løpebåndet og plattformen er tilstrekkelig smurt, er moderat stramt og ikke har for mye slitasje.</li> <li>3. Bytt omformer.</li> </ol>
E7	Overload protection	<ol style="list-style-type: none"> <li>1. Switch off for over 20 seconds and switch on again.</li> <li>2. Check if roller bearings are stuffed and not rotating freely inside front and rear rollers, check if running belt and running deck are well lubricated without excessive wear and tear, check belt tension is moderate.</li> <li>3. Replace inverter.</li> </ol>
E9	Incline error	<ol style="list-style-type: none"> <li>1. Check the incline sensor is well contact or not.</li> <li>2. Replace inverter.</li> <li>3. Replace incline motor</li> </ol>
Er	Inverter error	<ol style="list-style-type: none"> <li>1. Switch off for over 20 seconds and switch on again.</li> <li>2. Check the connecting line is well or not.</li> <li>3. Replace inverter.</li> </ol>
— —	Safety key not detected	<ol style="list-style-type: none"> <li>1. Check if safety key switch works, connecting wire works, or magnet inside works.</li> <li>2. Safety key is not connected correctly.</li> <li>3. Safety key is damaged, check and replace.</li> </ol>
No display on computer		<ol style="list-style-type: none"> <li>1. Check if power cable is connected to machine or change to another power outlet. If power switch is in position, test it by switch ON/OFF. If the power switch is burned out, replace one and make sure there's power to machine</li> <li>2. Check cable connection between computer and inverter.</li> <li>3. Replace inverter or computer.</li> </ol>

# IMPORTANT REGARDING SERVICE

**In the event of problems of any kind, please contact Mylna Service. We would like you to contact us before contacting the store so we can offer you the best possible help.**

Visit our website [www.mylnasport.no](http://www.mylnasport.no) - here you will find information about the products, user manuals, a contact form to get in touch with us and possibility to order spare parts. By filling out the contact form you give us the information we need to help you as effectively as possible.

Mylna Sport AS  
Ryghgata 4b  
3050 Mjøndalen  
Norway  
[www.mylnasport.no](http://www.mylnasport.no)  
Phone: +47 32272700